



D36.3 Technical Report #3 on 3D Display Techniques and Potential Applications

Project Number: 511568

Project Acronym: 3DTV

*Title: Integrated Three-Dimensional Television –
Capture, Transmission and Display*

Deliverable Nature: R

Number: D36.3

Contractual Date of Delivery: M45

Actual Date of Delivery: M47

Report Date: 30 July 2008

Task: WP12

Dissemination level: CO

Start Date of Project: 01 September 2004

Duration: 48 months

Organisation name of lead contractor for this deliverable: UNIABDN

Name of responsible: John Watson (j.watson@eng.abdn.ac.uk)

Editor: J. Watson (j.watson@eng.abdn.ac.uk)

30 July 2008

FINAL

3DTV Display Technologies and Potential Applications

TC5 Technical Report 3

EDITOR

John Watson

Contributing Partners to Technical Report:

Bilkent University (**Bilkent**)
Bremer Institut fuer angewandte Strahltechnik GmbH (**BIAS**)
Central Laboratory of Optical Storage and Processing of Information, Bulgarian Academy of
Sciences (**CLOSPI-BAS**)
De Montfort University (**DMU**)
Fraunhofer Gesellschaft zur Förderung der angewandten Forschung e.V. (**FhG-HHI**)
FogScreen Inc. (**FogS**)
Institute of Media Technology, Technische Universitaet Ilmenau (**UIL**)
Tampere University of Technology (**TUT**)
Informatics and Telematics Institute, Centre for Research and Technology Hellas (**ITI-
CERTH**)
Koç University (**KU**)
Middle East Technical University (**METU**)
Momentum Bilgisayar Yazılım Danışmanlık Ticaret A.Ş. (**Momentum**)
Max-Planck-Institut fuer Informatik (**MPG**)
University of Aberdeen (**UNIABDN**)

REVIEWER

Tarık Reyhan (**Bilkent**)

Project Number: 511568

Project Acronym: 3DTV

Title: Integrated Three-Dimensional Television – Capture, Transmission and Display

TABLE OF CONTENTS

<i>Executive Summary</i>	<i>1</i>
WP12 Priority Tasks and Publications	3
Achievements of WP12	3
WP12 Integration	5
Requirements for a 3D Display	5
SWOT Analysis for 3D Displays and Applications	6
Summary	7
1 Introduction	11
2 Overview of Work Accomplished: Task Summaries	13
2.1 RoadMaps (Tasks 1, 2, 3 and 19)	14
Task 1: Roadmaps for Holography and Underlying Technologies	15
Task 2: Roadmap for Autostereo	22
Task 3: A Roadmap for Applications	30
Task 19: A RoadMap for Education	41
2.2 Holography and Autostereo (Tasks 4, 5, 6, 7, 9 and 13)	43
Task 4: Compact RGB lasers or LEDs	44
Task 5: Future SLM Developments	48
Task 6: VLSI Technology	54
Task 7: New SLM Materials	57
Task 9: Hardware & Software for Head-tracking	63
Task 13: Underlying Micro-optical and MEMS Technologies	67
2.3 Human Factors (Tasks 8 and 10)	74
Tasks 8 & 10: Human Factors	75
2.4 Applications (Tasks 11, 12, 13, 14, 15, 16, 17)	85
Task 11: Football-related Applications	86
Task 12: Air Traffic Control Applications (of 3DTV)	89
Task 14: Motion Capture Using Standard Video Cameras	93
Task 15: Cultural Heritage	97
Task 16: Wildfire Simulation on 3D-GIS Environment	101
Task 17: Applications in the mobile domain	106
2.5 Market Survey	113
Task 18: Consumer Market Survey	114
3 Papers and Summaries	115
3.1 General	115
3.2 Holography	115
3.3 Autostereo	118
3.4 Applications	120
3.4.1 Cultural Heritage	120

3.4.2	Fire Propagation Simulation and Modelling.....	121
3.4.3	2D-Immaterial Displays.....	122
3.4.4	Holography in Life Sciences.....	124
4	<i>Conclusions</i>	129
5	<i>ANNEX (References for 3DTV Partners)</i>	130

Executive Summary

Author: John Watson

In the four years since the initiation of our Network of Excellence in 3DTV, worldwide activity in 3D displays, vision and associated applications has increased dramatically. The prospect of 3DTV in the home and the associated development of a host of related commercial and industrial applications have grown ever closer. New implementations of displays have appeared, new techniques have been pioneered and a wide range of applications has been generated to exploit this technology. However, it is still true to say that no particular technique or technology has yet stamped its dominance on the market place; autostereo methods still vie with the embryonic holographic techniques for a market share. Although several displays carry the “holography” name, none of them is a true implementation of 3D as envisaged by this NoE. It is still the case that in the short to medium term, displays based on stereoscopy (with glasses) and auto-stereoscopy are still likely to dominate for several years to come. A true interactive, full colour holographic TV in the home or workplace is still a long way away. At the recent 3DTV Conference in Istanbul (May 2008) [1], it was significant that many of the “big-players” in display technology discussed their plans for displays based upon stereo and autostereo; holography was conspicuous by its absence! This does not mean, however, that there is no worldwide activity in holography. Far from it; if anything, work on holography is gathering pace especially for niche applications. It is tempting to ask, though, whether a totally holographic display will ever happen, or are we most likely to see a seamless merging of stereo into autostereo and into multiview stereo and into a hybrid holo-autostereo display. This (undefined) “near-holographic” display would combine the best features of both, and this may well be enough for many applications of 3D.

We (in WP12) have long held the belief that the display is the key element in any move towards public, commercial and industrial acceptance of 3D vision, and this view has not changed. The applications that are beginning to appear are dependent on the performance and cost of the available display technology. A display, which suits one application, may not suit another. For instance, a fully interactive holographic display may be ideal for medical applications but over-specified for watching a 3D movie. Factors affecting human acceptance or perception of 3D are crucial to approval by the public: a TV in the corner of a room presenting virtual image maybe acceptable to some whereas others may want full real-image projection. The debate surrounding the need or acceptance of visual aids (such as glasses or head-mounted tracking devices) is far from settled.

It may be instructive here to reproduce a diagram (Figure ES-1) from a previous report [WP12-TR2], which serves to remind us of some of the main display types available today or in development. The main contenders today for a 3D display are holographic, volumetric, autostereo, and head-mounted technologies (HMD) which utilise vision aids. As was pointed out earlier, many of the current developments of 3D favour stereo with head mounted vision aids. It is likely that the ultimate display will be some sort of hybrid technology incorporating the best features of holography and autostereo.

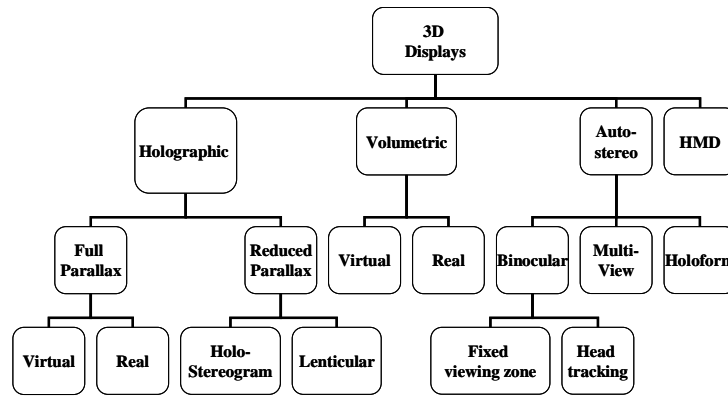

Figure ES-1: Outline of 3D Display Types [after WP12-TR2]

In the lifetime of this network, we have seen the arrival in the marketplace of stereo and pseudo-holographic displays from *Philips* [2], *SeeReal* [3], *Holografika* [4] and *Sharp* [5] to name but a few. In particular, *Philips* screened a Jean Michel Jarre concert to a private audience in 3D without glasses using their stereo-3D conversion tool “Bluebox” in conjunction with their “WOWvx3D” display. The *SeeReal* display is holography-based and utilises a limited “viewing window technology” to transmit a reduced numerical aperture to the eye (again without glasses). *SeeReal* also offer a range of autostereo displays [6]. The *Holografika* display also purports to be holographic in nature; images are replayed from a series of 3D arrayed voxels to give the illusion depth. Engineers at *Stanford University* are developing a 3D camera [7] incorporating 12,616 lenses which is itself a development of an earlier “light-field” camera.

Three-dimensional movies using a variety of vision-assists are becoming commonplace: the *BBC* screened a live Rugby International between Scotland and England in 3D-stereo using glasses to a limited audience [8]; other related news items from the *BBC* include a U2 concert recorded in 3D. This was produced by *3DFirm* [9], a consortium of companies involved in the production of 3D movies and TV productions. Versions of *Bugs*, *Jaws*, *Shrek*, and *Beowulf* were released in stereovision. *Beowulf* was screened to the 3D-TV CON delegates in Istanbul in May 2008. The *Disney Corporation* announced the creation of six new animated 3D movies by 2012 [10].

Representatives from *Philips*, *Texas Instruments*, *Mitsubishi* and *Holografika* displayed or talked about their latest developments and their hopes for the future of 3DTV at the aforementioned 3DTV-CON in 2008. It is clear that these companies believe in the future of 3D and are putting significant resources into its development. *Mitsubishi* talked about their particular 3DTV to be released later this year (2008). The same company are also planning the release of a 3D blu-ray gaming module [11]. What was particularly significant was that these companies (with the exception of *Holografika*) are currently basing their designs on stereo and autostereo: holography was barely mentioned. For autostereo and some implementations of holography, headtracking is a vital element of the display and available techniques are becoming more user-friendly, less intrusive and cheaper (see, for example [12]).

Holography, though, is not standing still. Much activity is going on worldwide to further the development of holographic systems. Without mentioning members of our

NoE, groups that are particularly active include, the *University of Connecticut* [13] and the *Media Lab MIT* [14] in USA; the *Electronics and Telecommunications Research Institute (ETRI)* [15] and the *Korea University of Science and Technology* [16] in the Republic of Korea, and the *Advanced Telecommunications Research Institute International (ATR)* [17] in Japan. Companies active in utilisation of holography include, as mentioned earlier, *Holografika* and *SeeReal*. Clearly, though, for holography to become a real prospect, the underlying technologies need to be developed to a higher level than at present. SLMs and LCD panels need to be developed to higher pixel density and smaller pixel size. VLSI technologies continue to grow at a rate consistent with the so-called “Moore’s Law” and spatial light modulators (SLMs) are improving in resolution and overall dimensions [18]. A good overview of Laser TV (both autostereo and holographic) is given in *Wikipedia* [19].

In this report, we describe the activity of the WP12 group and how this work relates to the developments in 3DTV.

WP12 Priority Tasks and Publications

At an early stage in WP12, we identified several priority work areas, with others added later, where we felt the work of the group should concentrate (the detailed Task list is given in Section 1). These priority Tasks include roadmaps for holography, autostereo, applications and education (Tasks 1-3, 19). Underlying technologies such as RGB lightsources, SLMs, VLSI, new materials, hardware/software and micro-technologies (Tasks 4-7, 9, 13) are other areas of priority. Human factors are covered in Tasks 8 and 10; whereas a range of potential applications is outlined in Tasks 10-12 and 14-17. Finally, a consumer market survey is the remit of Task 18. It is under the headings of these Tasks that we describe the progress made by members of WP12, and how this research relates to work in the wider context (Section 2).

As is now traditional for our network reports, we present a summary of the latest publications by members of WP12 since TR2, relating specifically to holographic and autostereo displays, associated human factors and applications. We also include a personal (Editor’s) assessment of their contribution and impact on the general landscape of 3DTV. The abstracts for these papers are presented in Section 3 and the full texts can be found in the Appendices. A look at the list of recent publications has shown that the number of papers published since the last technical report has decreased. This is due, partly to the shorter timeframe covered by this report, and partly to the publication of longer, more detailed and more comprehensive papers. However, the quality and potential impact of the publications on the wider stage remains high. Many of these papers appeared in top-rank journals, while more appeared at conferences around the world underlying the increasing impact of our network on the world of 3DTV. Of 34 publications included (and in press) 25 are in conference proceedings (including 3DTV-CON, Istanbul), 8 are in peer-reviewed journals and one is a patent application. Increasing numbers of papers (19) are joint contributions between two or more NoE partners (often across workpackages) and often with collaborators outwith the network. Table ES-1 shows a breakdown of where these papers appeared in relation to author institutions.

Achievements of WP12

From the Task reports and the associated publications we see that over the course of the NoE, members of WP12 have been instrumental in attaining some significant

achievements in displays and applications; both internal to the Network and in the wider, global context. Figure ES-2 graphically illustrates some of these.

The aforementioned roadmap concept introduced by members of this workpackage has matured into a very useful and meaningful management and progress evaluation tool. Following our implementation of the technique, roadmaps have been rolled out into other workpackages.



Figure ES-2: Some WP12 Achievements

There has been significant growth in the associated technologies required for 3D to make its impact. Through the mechanisms of the network, two well-developed laboratories were established at *Aberdeen* and *Bilkent Universities* for the development of SLM applications and several papers (*Aberdeen University*, *Bilkent University* and *MPG*) were published on the use of SLMs in computer generated holography and 3D displays (Task 5 Report & Sec 3 - Papers 2, 4, 5). *CLOSPI-BAS* have taken another approach by advancing our knowledge of photopolymer materials for SLMs (Task 7 Report; & Sec 3 - Papers 7, 8). Implementation of head tracking technology is an area our Network partners have been particularly influential in: the *Heinrich Hertz Institute* and *deMontfort University* have co-operated in the development of a new interactive autostereo display and have made significant contributions to head-tracking techniques (Task 9 Report & Sec 3 - Papers 9 to 14). *BIAS* are leaders in the world of optical metrology and laser development and have led our look at the evaluation of RGB sources needed for a 3D colour display (Task 4 Report).

FogScreen, has seen their “immaterial” display (Tasks 8, 9, 10 Reports & Sec 3 - Papers 21 to 24) appear in the *Eurovision Song Contest* and used by many companies around the world such as *Disney*, *Nokia*, *Procter & Gamble*, *Motorola*, *Sony*, *Siemens* and *Microsoft*. *Tampere University of Technology* and the *University of Ilmenau* are studying aspects of human factors and perception (Tasks 8, 10 Report & Sec 3 - Paper 25), which is a vital aspect if 3D is to gain widespread acceptance.

The rate of growth of available applications is no less impressive and again our own partners are in the vanguard here (Tasks 11 to 17 & Sec 3 - Papers 15 to 20, 26 – 34). *ITI-CERTH*, *Koc University*, *METU* and *Yogurt* have all been influential. *Aberdeen University* has been involved in the development of subsea holographic cameras for plankton measurements. We have been instrumental in pursuing several unique applications of 3D technology from football-related visualisation through forest fire simulation to subsea holography of plankton (Tasks 10 to 12 and 14 to 17). Although

some of these applications had begun before the onset of the network and are outwith its remit, they are again a testament to the ingenuity and forward-thinking capacity of the group as a whole. Another point of note is the preparation, by *Momentum*, of a market survey of users' expectations for a 3D display (Task 18 & [35]).

WP12 Integration

As far as the network itself is concerned, and the WP12 participants in particular, we have seen the continued integration of partner activities that we reported on in WP12-TR2. The level of student and researcher exchange between WP12 partners has increased as has inter-WP exchanges and exchanges out with the network. This is a testament to our growing integration. This has now reached a level that can sustain itself beyond the life of the network. Table ES-2 summarises the exchanges that have taken place since the last NoE.

Several of our participants have formed groups (sometimes with outside partners) that have applied for, and received, prestigious funding awards from national or international bodies. Table ES-3 lists some of these projects and the consortia, several more are in preparation.

Requirements for a 3D Display

The key elements required in the development of 3DTV, viz. scene capture, scene representation, coding, transmission and the display, are described in earlier reports. Clearly, those systems and applications that require only a few of the above elements for their implementation are likely to be realised at an earlier stage than those needing the complete system. However, for true, realistic implementations of 3D many other factors, such as human perception, price and reliability of the equipment, image resolution, broadcast standards, and availability of material to be broadcast have to be taken into account.

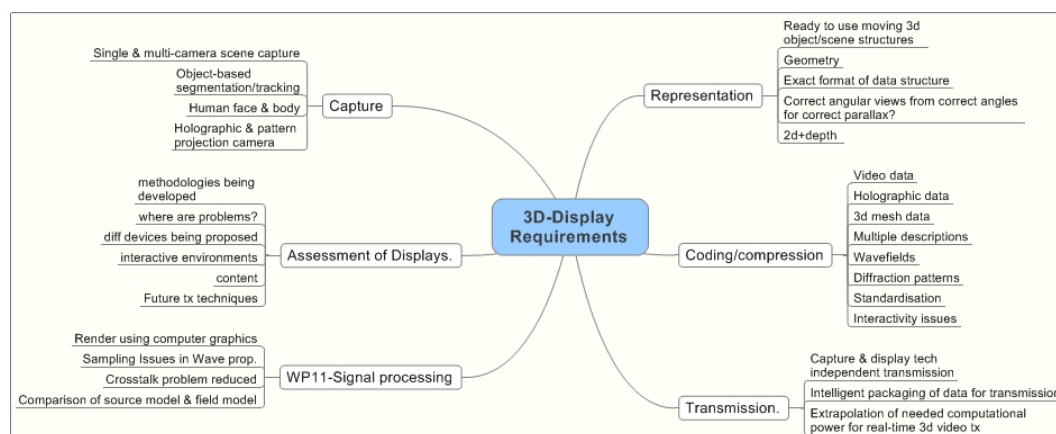

Figure ES-3: Future Requirements of a 3D Display

At the last General Research Meeting of the network [20], consideration was given to what a 3D display requires in terms of scene capture, coding, transmission and the like. In Figure ES-3, we explore the inter-relationships in more detail and outline what is required from these other technical areas if 3DTV is to reach its goal.

An important aspect is how the public will perceive and relate to 3DTV; what form will a display take; will it require vision aids; how will human factors such as comfort and accommodation affect our perception. These aspects need answered over the next few years. Will 3D capture be holographic or some combination of 2D cameras? Certainly, holography has some significant barriers that may be insurmountable such as laser safety and laser parameters. For scene representation, what is the exact form of the data structure, can correct angular views be created with the correct angles for accurate parallax information? In coding and compression, standardisation needs addressing and how holographic data is to be handled. Finally, for data transmission, how can intelligent packaging of data is to be handled. These questions and more have been posed but most, as yet, remain unanswered.

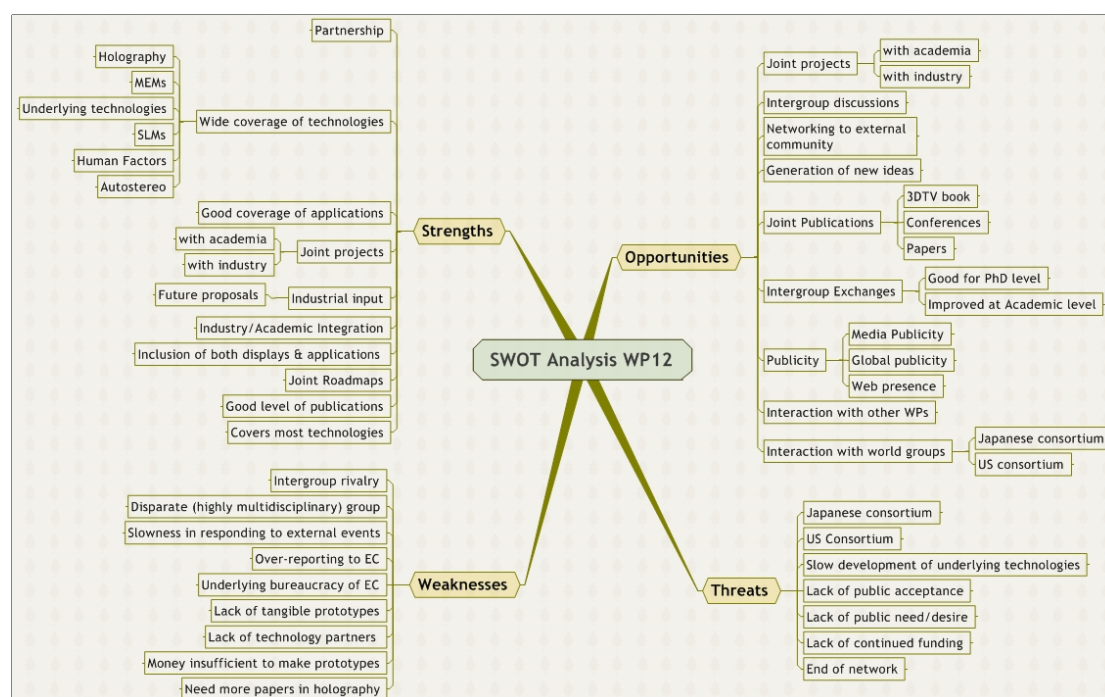

Figure ES-4: SWOT Analysis of WP12

SWOT Analysis for 3D Displays and Applications

For the 3DTV last review meeting [21] a SWOT analysis (Strengths, Weaknesses, Opportunities and Threats) was presented for WP12. A revised and up-dated version of this is given in Figure ES-4. The diagram is self-explanatory but some points can be highlighted. The overriding strength of WP12 is its wide coverage of current 3D technologies and potential applications; the WP12 group after a relatively slow start showed a high degree of integration, interactivity and interaction. The introduction of roadmaps was an early strength of WP12. Its weaknesses are, paradoxically, this wide coverage: it is very difficult for a small group to be equally effective in all areas and to respond quickly to external developments. Another weakness, which did detract from the efforts of the participants, was over-reporting and the underlying bureaucracy of the EC. The network offered opportunities for partners to exchange ideas and personnel and again, after a slow start, the partners of WP12 embraced this with enthusiasm and several exchanges resulted in publishable work. WP12 partners also took the opportunity to publish a wide range of work in high-level journals and at conferences. Many joint projects have been spawned between network partners and

with outside organisations and this is to be commended. The threats lie in potential lack of interaction with other groups and consortia on the global stage. This has tended not to happen as many of our partners also participate in the global networks and have active research links with worldwide research organisations and businesses. Of course, the ending of the 3D network could blunt future activities but the level of integration that the NoE has fostered should serve to negate this threat.

In terms of the Network as a whole then the major strength is the bringing together of partners across a wide range of areas who might never have had the opportunity to interact. The reporting and EC bureaucracy could be seen as a weakness affecting the whole network. The opportunities to interact and move into new areas were grasped by the whole Network and the major threat is the end of the network.

Summary

In summary, the success and impact of the work in WP12 has had, and is continuing to have, far-reaching influence across the whole gamut of worldwide 3DTV and vision. We have made significant progress in the development of our field. The Task summaries and associated papers offer an overview of progress made by the network in displays and applications. We believe that the 3DTV Network has proven to be a catalyst to pave the way for the development of the associated display technologies and their applications over the next ten years.

References

1. Conference Proceeding 3DTV-CON (Istanbul 2008)
2. Philips 3D Solutions, <http://www.business-sites.philips.com/3dsolutions>
3. SeeReal Technologies, <http://www.seereal.com.seereal.com>
4. Holografika, <http://www.holografika.com>
5. Sharp, http://www.sle.sharp.co.uk.research/optical_imaging/3d_research.php
6. SeeReal Technologies, Autostereo, <http://www.seereal.com.seereal.com>
7. Stanford 3D camera, <http://news-service.stanford.edu/news/2008/march19/camera%20-031908.html>
8. BBC News, <http://news.bbc.co.uk/1/hi/technology/7213534.stm> and <http://news.bbc.co.uk/1/hi/technology/7286852.stm>
9. 3DFirm, http://www.inition.co.uk/wowlab_3dfilm.htm
10. Disney, <http://news.bbc.co.uk/1/hi/entertainment/7338320.stm>
11. Mitsubishi: <http://www.mitsubishi.com>; http://crave.cnet.com/8301-1_105-9764622-1.html; <http://www.tvpredictions.com/mitsu3d092507.htm>; <http://www.engadget.com/2008/01/04/mitsubishi-shows-off-3d-tv-technology-no-glasses-needed/>
12. Johnny Chung Lee, Head tracking using Wii Remote, <http://www.cs.cmu.edu/~johnny/projects/wii>
13. Univ. of Connecticut, Bahram Javidi, <http://www.ee.uconn.edu/javidi.php>
14. MIT Media Lab, <http://www.media.mit.edu/>
15. ETRI, Korea, <http://www.etri.re.kr/eng/>
16. Korea University of Science and Technology, <http://www.ust.ac.kr/eng/index.html>
17. ATR Japan, http://www.atr.jp/index_e.html
18. Holoeye, <http://www.holoeye.com>
19. Laser TV, http://en.wikipedia.org/wiki/Laser_TV
20. 3DTV-GRM Stuttgart, Feb 2008, <https://www.3dtv-research.org/internal/internal.php>
21. 3DTV-Review Meeting, Aberdeen University, November 2007, <https://www.3dtv-research.org/internal/internal.php>

First author	Institution	Journal.	Conference.	Book/Other	Ref
Benzie	AU, FogS, HHI, DMU, BIAS, Koc, CLOSPI	IEEE CSVT (2007)			1
Ahrenberg	MPI, AU	App Optics (2008)			2
Sayinta	Koc		3DTV-CON 2008		3
Yucesoy	BU		3DTV CON 2008		4
Yaras	BU				5
Stoykova	CLOSPI		3DTV CON 2008		6
Yovcheva	<i>Plovdiv U, DIT, CLOSPI, CLP</i>	J Opt & Adv Mat	Condensed Matter (2008)		7
Yovcheva	<i>Plovdiv U., CLOSPI</i>	J Opt & Adv Mat	Condensed matter (2008)		8
Buckley	<i>LBO, DMU</i>		SID Conf 2008		9
Sexton	DMU, <i>LBO</i>		IMID Conf (2008)		10
Surman	DMU, HHI, <i>LBO, Sharp</i>		3DTV-CON 2008		11
Surman	DMU, HHI, <i>LBO, Sharp</i>		ASID'07		12
Surman	DMU, HHI, <i>LBO, Sharp</i>	Jnl SID			13
Hopf	HHI		3DTV-CON 2008		14
Zabulis	<i>FORTH, ITI, METU,</i>		3DTV-CON 2008		15
Bastanlar	METU, ITI, <i>FORTH</i>		3DTV-CON 2008		16
Bastanlar	METU, ITI		ISPRS 2008		17
Kose	BU, ITI, METU		3DTV-CON 2008		18
Kose	BU, ITI, METU		IU2008		19
Kose	BU, METU, ITI		ISPRS 2008		20
Olwal	<i>KTH, UCSB, FogS, TUT</i>		INTETAIN 2008		21
Rakkolainen	FogS		3DTV CON 2008		22
Rakkolainen	TUT (FogS)		SID Conf 2008		23
Rakkolainen	FogS			Patent App	24
Jumisko-Pyykko	TUT, FogS		3DTV-CON 2008		25
Sun	AU	J Oceanic Eng (2007)			26
Sun	AU	Phil Trans Roy Soc (2008)			27
Sun	AU		OCEANS07		28
Burns	AU		OCEANS07		29
Veitch	AU		OCEANS07		30
Benzie	AU		OCEANS07		31
Dyomin	<i>Tomsk SU, AU</i>		OCEANS07		32
Sun	AU	J Biomedical Opt (2008)			33
Sun	AU		OSA (2008)		34

Table ES-1: Publications by Institution [Institutions shown in *italics* are not members of 3DTV-NoE]

Sending Institution	Researcher	Host Institution	Dates/Duration	Topic
Aberdeen Univ	J Watson	CLOSPI-BAS	Feb 2008 (5 d)	Gen research in holography
Aberdeen Univ	J Watson	CLOSPI-BAS	Jun 2008 (2 d)	Holog in cultural heritage
BIAS	C vonKopylow	CLOSPI-BAS	Jun 2008 (2 d)	Holog in cultural heritage
BIAS	C vonKoplow/C Fallforf	Aberdeen Univ	Oct 2007 (5 d)	Gen research in holography
BIAS	M Agour	Bilkent Univ	Feb 2008 (2 w)	Reconstruction from SLM
BIAS	C Falldorf	TUT	Sep 2007 (2 w)	Wavefield reconstruction
Bilkent Univ	Ali Özgür Yöntem	Koc University	July 2007 (4 w)	Optical Design
CLOSPI-BAS	V Sainov/S Sainov	Koc University	Nov 2006 (4 d)	Digital interferometry
CLOSPI-BAS	S Sainov	Dublin Inst of Tech	Apr 2008 (2 w)	Photopolymer recording
DMU	P Surman	CLOSPI-BAS	Sept 2006 (2d)	Discuss future projects
DMU	P Surman	Bilkent Univ	Nov 2006 (3d)	Optical design
DMU	P Surman	Koc Univ	Nov 2006 (1d)	Discuss future projects
FhG-HHI	K Hopf	DMU	Aug 2007 (2 d)	Exploitation of Displays
FogScreen	I Rakkolainen	Univ of Ilemenau	Jun 2007 (2 d)	Display experiments
FogScreen	I Rakkolainen	Univ of Tuebingen	July 2007 (2 d)	
FogScreen	I Rakkolainen	Tampere Univ of Tech	Aug 2007 (1 d)	Organisation of TC
ITI	N Grammalidos	Bilkent	Oct 2007 (1 w)	Wildfire Simulation
ITI	A Koutsia	METU	Oct 2007 (1 w)	Football applications
METU	V Bastanlar	ITI	Aug 2007 (6 d)	Virtual Tour
METU	E Cetin	ITI	Jun 2008	Wildfire
METU	Y Cetin	ITI	Jun 2008	Virtual Tout
Momentum	Tanju Erdem	FogScreen	Aug 2007 (1 d)	Applications of FogScreen
MPI	L Ahrenberg	Aberdeen Univ	Nov 2007 (2 w)	SLM experiments

Table ES-2: WP12 Exchanges

Project	Partners	Funding Body	Amount	Period
YOCAP – Motion Capture System with Standard Video Cameras	Yogurt, Koc U.	Turkey - TUBITAK	\$180,000	1/11/07 – 1/3/2009
MUTED – Multi-user 3D TV Display	DMU, FhG-HHI, <i>Sharp Europe, TU Eindhoven, U West Bohemia, Light Blue Optics, Biotronics 3D</i>	EC	€4.8 M	1/7/06 – 31/12/08
HELIUM3D – High Efficiency Laser-based Multi-user Multi-modal 3D Display	DMU, Koc U., FhG-HHI, <i>Philips, Barco, U. College London, T.U. Eindhoven, Nanjing U.</i>	EC	€2.9 M	1/1/08 – 31/12/10
Virtual	U. West Bohemia	Czech Min of Educ	€423 k	2006 - 2011
LC CPG	U West Bohemia, <i>TU Prague, Masaryk U, TU Brno,</i>	Czech Min of Educ	€1885 k	2006-2011
Mobile 3DTV	<i>Tamlink, TUT, FhG-HHI, TU Ilmenau, MMS</i>	EC	€2.5 M	1/1/08 – 31/12/10
3D reconstruction & virtual tour	METU, ITI-CERTH	TUBITAK & GSRT	€23,500	1/10/06 – 31/9/08
Video-based smoke & fire detection	Bilkent, ITI-CERTH	TUBITAK & GSRT	€23,500	1/10/06 – 31/9/08
3DPHONE	Bilkent U, FhG, <i>Telefonica, Holografika, Streamezzo, Helsinhgin</i>	EC	€4.8 M	1/2/08 – 31/1/11
REAL 3D	<i>Oulun Yliopisto, Poly Warsaw, NU of Ireland, CNDR, Lausanne Poly, Bilkent U, BIAS, Lyncee Tec</i>	EC	€5.87 M	1/2/08 – 31/1/11

Table ES-3: Grants awarded to NoE Members[Institutions shown in *italics* are not members of 3DTV-NoE]

1 Introduction

In this final report from Work Package 12 (Technical Committee 5): Displays and Applications of the 3DTV Network of Excellence we present an overall assessment of where 3DTV displays and their applications are today, as well as bringing the previous reports up-to-date. As in earlier reports, we adopt a broad-based approach to the concept of 3DTV and consider as many aspects of 3D displays and applications as possible. We include the latest publications by members of WP12 since TR2, with a personal (Editor's) assessment of their contribution and impact on the general landscape of 3DTV displays and applications. The structure is slightly different from these previous reports in that we have chosen to present our overview of current progress in terms of the major tasks outlined in the last DoW:

Task 1: A road map for holographic displays and underlying technologies

Task 2: A road map for autostereoscopic displays

Task 3: A road map for representative applications

Task 4: Evaluation of RGB laser/LED sources for 3D-displays

Task 5: Evaluation SLM technologies for 3DTV and related applications

Task 6: Investigation VLSI Technology and targets for the future

Task 7: Evaluation of new materials (PDLC's) for SLM's

Task 8: Evaluation of human factors related to autostereo and holographic displays

Task 9: Evaluation of hardware/software requirements for multi-user head tracking systems

Task 10: Investigation of interactivity of 3D application systems and their usability, together with related human factors

Task 11: Multi-target Tracking from Multiple Views for Football-related Applications

Task 12: Air Traffic Control Applications (of 3DTV)

Task 13: Evaluation of underlying micro-optical and micro-mechanical technologies for 3D displays

Task 14: Motion Capture System Using Standard Video Cameras

Task 15: 3D Reconstruction algorithm for a virtual tour system of cultural heritage

Task 16: Wildfire Simulation on 3D-GIS Environment

Task 17: Technologies and applications of 3DTV to the mobile domain

Task 18: Preparation of a consumer market survey on 3DTV technology

Task 19: A roadmap for use of 3D in Education

Tasks 14 to 19 are new since the publication of TR2 and Tasks 18 and 19 are additional to those listed in the final DoW.

It also helps to show how these tasks relate to each other and to the generic themes of previous reports:

Roadmaps: Tasks 1, 2, 3 and 19

Holographic Displays: Tasks 4, 5, 6, 7 and 13

Autostereo Displays: Tasks 4, 5, 6, 7, 9 and 13

Human Factors: Tasks 8 and 10

Applications of 3D: Tasks 10, 11, 12, 14, 15, 16 and 17

Market Survey: Task 18

In the now traditional manner of our network reports, we present a summary of the latest publications by members of WP12 since TR2, relating specifically to holographic and autostereo displays, associated human factors and applications. We also include a personal (Editor's) assessment of their contribution and impact on the general landscape of 3DTV. The abstracts for these papers are given in Section 3 and the full texts can be found in the Appendices.

Under the headings of these Tasks, we summarise the progress made by members of the consortium, how the work relates to the more global picture and how it may develop in the future (Section 2). Together with the papers published and included here, we hope that these summaries will offer an overview of progress made by the network in displays and applications. We believe that the 3DTV Network has proven to be a catalyst to pave the way for the development of the associated display technologies and their applications.

2 Overview of Work Accomplished: Task Summaries

At an early stage of the WP12 (TC5) work programme a series of important tasks were defined which are key to the development of a 3D display or the success of some representative applications. The diagram below (Figure 2-1) shows these tasks, how they link to each other and how they relate to the work of other WP's.

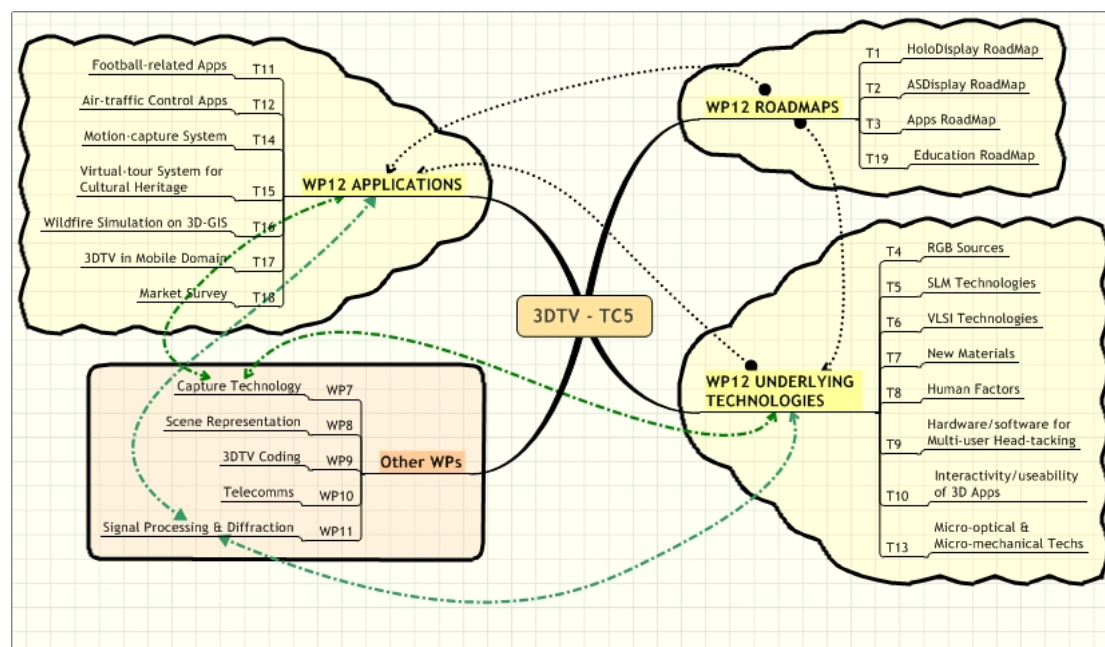

Figure 2-1: WP12 (TC5) Tasks and their Inter-relationships

The roadmap concept introduced by members of this workpackage has matured into a very useful and meaningful management and progress evaluation tool. Following our implementation of the technique, roadmaps have been rolled out into other workpackages. We show updated roadmaps for the three main topics of holographic displays and underlying technologies [Task 1], autostereo displays [Task 2] and representative applications [Task 3] and, new in this report, a roadmap for development of 3D in education [Task 19].

Because of the relative maturity of autostereo displays compared to holography, and the experience of our autostereo partners, this group has been particularly successful in the level and nature of its advances. For instance, several improvements in headtracking were introduced [Task 9]. Other advances are in the evaluation of RGB sources needed for a 3D colour display [Task 4]. Through the mechanisms of the network, two well-developed laboratories were established for the development of SLMs applications [Task 5]. Through these laboratories, several papers have been published using SLMs in computer generated holography and 3D displays. Another partner is advancing knowledge in photopolymers [Task 7]. Our network partners are at the forefront of research into the implications of human factors and means of evaluating and quantifying such factors [Tasks 8 and 10].

We have been instrumental in pursuing several unique applications of 3D technology from football-related visualisation through forest fire simulation and a unique display

based on a sheet of fog to subsea holography of plankton [Tasks 10-12 and 14-17]. Although some of these applications had begun before the onset of the network, they are again a testament to the ingenuity and forward-thinking capacity of the group as a whole.

2.1 RoadMaps (Tasks 1, 2, 3 and 19)

A roadmap serves many purposes and there are several approaches to its implementation. Our concept is that a well-structured and thought-out roadmap will enable the monitoring of progress in a given area of technological development. It will identify the key technologies needed to help the development to progress, and will assist in predicting timescales for the technology to reach fruition. Perhaps more importantly of all it will help to identify prospective roadblocks, which are preventing progress and indicate areas of essential improvement and those that we can circumvent. They can also assist in identifying areas of potential future impact. Although we do not claim that our roadmaps will accomplish all of these aims, we do believe that they are an important tool in assessing the growth of 3D TV and its applications.

Roadmaps are outlined here for holographic displays and associated underlying technologies (Task 1), autostereo displays (Task 2), applications (Task 3) and the use of 3D in education (Task 19). In some ways, the division is somewhat arbitrary and in truth, the roadmaps merge into each other, since we are all aiming for a common goal. Because of the vast array of potential applications of 3D, the applications roadmap concentrates on a small, but representative set of areas of activity, such as 3D football visualisation, forest fire simulation, subsea holography and air traffic control. In the preparation of the roadmaps, we have tried to be neutral and objective in our assessment of the development and not to promote, unreasonably, our own particular themes or areas of activity. The roadmaps, of course, have relevance to all of the tasks in the underlying technologies and applications, but also have some impact on other WPs, particularly WP11 (TC4) and WP7 (TC1).

For the applications section, the roadmaps concentrate on an estimate of the timescale for technology commercialisation (although at times subjective). The roadmaps are projected over the next 15 years, which can be split into three stages:

- **Stage 1:** Tasks and technologies that are currently active and involve core research for the specific application.
- **Stage 2:** Areas that the technology is likely to progress towards as it matures. This stage is where likely future joint projects and grant applications will be aimed.
- **Stage 3:** Finalisation of some applications.

Milestones, technological requirements and goals are shown. Clearly, no display method is without its problems or limitations. The development paths which have to be followed are complex and interlinked. It should be borne in mind though that such maps and timelines are indicative and dynamic: they will change as technology and techniques develop and cannot take into account the next “new idea”.

Task 1: Roadmaps for Holography and Underlying Technologies

A roadmap for the development of a holographic display and underlying technologies

Participants: UNIABDN, Bilkent, BIAS, CLOSPI-BAS, KU, DMU. FhG-HHI

Authors: J Watson and P Benzie

This is an updated and revised version of the roadmap given in WP12-TR2

A fully holographic display is deemed by many to be the “ultimate” 3D-display. A holographic display will inevitably rely on digital methods and spatial light modulation. Digital holography enables the recording, transmission, encryption and compression of holographic data. However, the quality of reconstruction is dependant on the availability of high resolution spatial light modulators (SLMs) and charge-coupled devices (CCDs). A spatial light modulator is required to modulate the amplitude or phase modulation of the incident beam with the spatial pattern written onto the SLM. The spatial pattern is generated from an interference pattern obtained using computer generated holography (CGH) or captured from a CCD sensor. Holography is reliant on the development of suitable SLMs to provide an adequate spatial bandwidth product (SBP).

A Timeline for the Development of a Holographic Display

As an example of the development path that may take place and the steps that need to be taken on the way, we can consider the development of a large, wide-angle, full colour, full parallax, moving, interactive holographic display for television. We can draw a rough timeline (Figure T1.1) through to completion of such an objective. It is clear that to reach such a goal a series of incremental improvements are needed on the way, particularly in the development of support technologies.

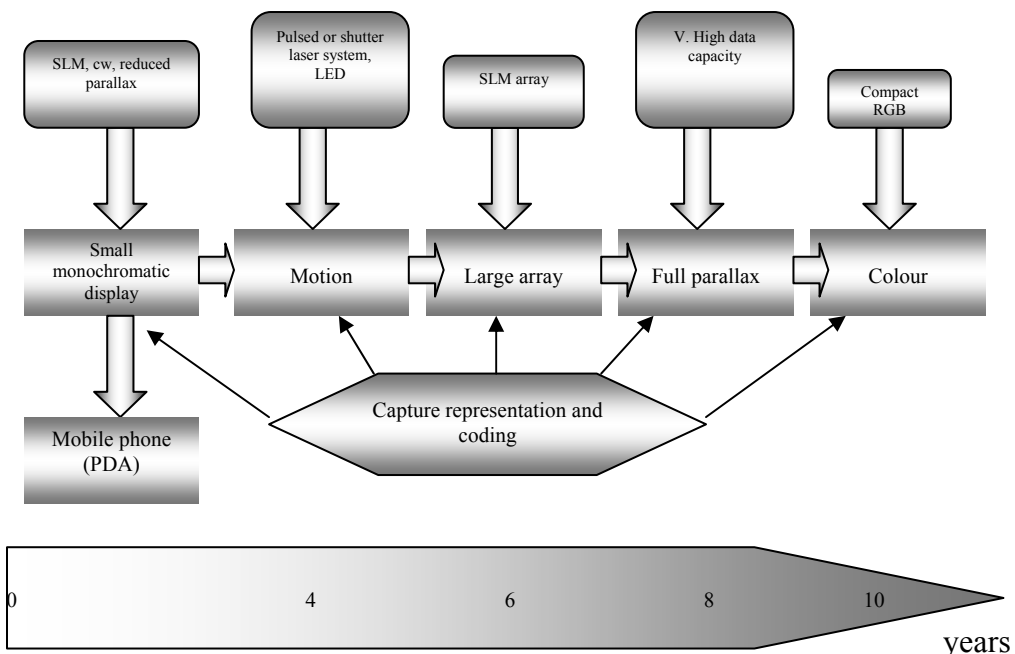

Figure T1.1: An indicative timeline for a holographic display [from WP12-TR2]

A holographic display will inevitably rely on digital electronic techniques and employ some method of spatial light modulation. Digital holography enables the recording, transmission, encryption and compression of holographic data. However, the quality of image reconstruction is dependant on the availability of high-resolution spatial light modulators (SLMs) and charge-coupled devices (CCDs) or complementary metal oxide semiconductor (CMOS) sensors to provide an adequate spatial bandwidth product. An SLM modulates the amplitude or phase of the incident beam with the spatial pattern of light incident upon it. The spatial pattern may be created by a computer-generated hologram (CGH) or captured directly on an electronic sensor. Initially, development might be of a small (one SLM), monochromatic, static display. This could be suitable for a personal digital assistant (PDA) or mobile phone [following the appearance of these ideas in WP12-TR2, some members of our NoE consortium have taken up these ideas¹]. This would most likely use simple software and a continuous wave (cw) laser. The next required development stage could be to incorporate motion into the display; time modulation or a pulsed laser or LED would then be needed. A further incremental step is then a larger display employing either a single device or an array of interconnected SLM's (this could also come earlier or in parallel with other developments). To reach this stage, dramatic improvements in VLSI technology are necessary to allow smaller pixels and larger numbers, particularly if the next step is for a full parallax image. If the oft-quoted "Moore's Law" continues to apply then it could still be more than 8 years before a display of less than micron pixel size is achieved. The addition of full colour requires the development a compact, polychromatic, high-coherence laser. Such a display though cannot be developed in isolation. It is vital that, throughout this development, input is obtained from those involved in image recording and capture, scene representation, coding, transmission, compression and data conversion. Immediate goals are improvements in driver software and reconstruction algorithms. Of course, consideration must taken of the physical size and weight of the display; dramatic reductions are necessary for power supplies, lasers and drive units for example, particularly if a portable device is needed.

The timescale above allows ten years to develop a large, dynamic, interactive holographic display, based upon the rate of development in current SLM technology. A similar timeline could be drawn for a purely autostereoscopic or volumetric display. However, it is felt that the advances currently being made in auto-stereoscopic displays suggest that a multi-viewer, high resolution, bright display could be achieved two or three years earlier than a holographic one.

Roadmaps of Underlying Technologies

Clearly, as indicated above, to realise a 3D display, whether this be holography or stereo requires significant improvement in the underlying technologies. The roadmaps below [reproduced from WP12-TR2] highlight some of the necessary developments holographic and auto-stereoscopic development.

¹ Mobile3DTV and 3DPHONE projects funded by EC under FP7

Technologies – A/S.	2004	2006	2008	2010	2012	2014	2016	2018	Units	Ref
Binocular - Fixed Viewing Zones										
System efficiency									%	i
Blue saturation	1		2.5	5					lm/W	
Green Saturation	4		10	20					QE(x+y)	
Red Saturation	<0.33		<0.25	<0.22					CIE y	
Life from 300 Cd/m ²	>0.6		>0.7	>0.75					CIE x	
Max. pixel density	>0.65		>0.67	>0.7					H r s	
Contrast @ 500 lux	10K		20K	40K					Ppi	
Max. diagonal size	100		200	300					Years 2D	
Max. pixel no.	50		100	200						
Max. diagonal size	1M		5M	10M					inches	
Panel thickness	20		40	60					mm	
Max. voltage swings	2.0		1.0	0.5					V	
Panel weight	8		5	3					g/cm ²	
Fabrication costs	0.5		0.25	0.1					\$/inch ²	
	5.00		1.00	0.5						

Technologies – A/S.	2004	2006	2008	2010	2012	2014	2016	2018	Units	Ref
Binocular – Single user head tracked										
Single-user head tracker										ii
LCD vertical sub-pixels			adequate	robust	mature	mature				
Binocular – Multi-user head tracked										
Multi-person head tracker										iii
Steering backlight unit				available						
Suitable LC panel										
Scanned laser										
Multi-person head tracker										iv
MEMS scanner										
RGB laser source										
Light valve										
SLM										
Fast light valve for MP										
Fast SLM for MP										

Technologies – A/S.	2004	2006	2008	2010	2012	2014	2016	2018	Units	Ref
Multi-View Displays based on Large-sized Video Projection (non-tracked)										v
Multi-view video projector					1 st prototype	commercialization				
Direction selective screen					1 st prototype	Commercialization				vi
Image processing unit for rendering multiple views					1 st prototype	commercialization				
Multi-view Display based on Very high Resolution LC panels (non-tracked)										vi
Spatial resolution comparable to common standard TV (10 views including 'image flipping'), 10M pixels				1 st prototype		commercialization				
Spatial resolution comparable to common HDTV (10 views including 'image flipping'), 40M pixels							1 st prototype	commercialization		
Spatial resolution comparable to common standard TV (100 views no 'image flipping'), 100M pixels							?			
Spatial resolution comparable to common standard TV (100 views no 'image flipping'), 400M pixels							?			
Holoform - OLED displays										vi
Min. pixel size									µm	
Position accuracy	85	42			28	10			µm	
Uniformity	5	3			2	1			%	
	5	5			5	5				

Technologies – A/S. & Vol.	2004	2006	2008	2010	2012	2014	2016	2018	Units	Ref
Holoform – Dynamic parallax barrier										viii
Light valve speed		10k	3k		10k		>10k		frames	
Wedge@										
Barrier area		Under develop.	1 st commerc.		mature				cm	
		30 x 30	60 x 60		1000 x 40	1500 x 60				ix
Holoform – Quasi holographic										
HOE size		30 x 30	60 x 60		100 x 40	1500 x 80				
HOE cost		1000	500		250	250				
LED efficacy		10	20		30	40				
LV speed (frames/sec.)		10k	3k		10k	>10k				
LV speed (frames/sec.)										
Volumetric										x
Multi-layer (no. of layers)		30	40		80	160				
LV speed (frames/sec)		10k	3k		10k	>10k				
Pixel array size(voxels)		11 x 11 x 5	10 ² x 10 ² x 10 ²		>10 ² x 10 ² x 10 ²	10 ³ x 10 ³ x 10 ³				
Voxel capacity					Under develop.	Possible available				

Technologies – A/S. & Vol.	2004	2006	2008	2010	2012	2014	2016	2018	Units	Ref
Interactivity										xi
Gesture tracking (close-range tracking supporting hand & finger segmentation)				1 st prototype		commercialization				
Gesture tracking (increased detection area, extended gesture repertoire)					1 st prototype		commercialization			
Gaze (line of vision) tracking					1 st prototype		commercialization			
Facial Expression analysis					1 st prototype		commercialization			
HOE size					1 st prototype		commercialization			

Technologies – Holo.	2004	2006	2008	2010	2012	2014	2016	2018	Units	Ref
Spatial light modulator (LC)										
pixel size									µm	
Aperture	8		6		4			1	mm ²	
Refresh rate	400		1600		6400			25600	Hz	
synthesised pixel number	120		240		500			1000		
Field of view	2		4		8			16	Deg.	
	2		4		8			16		
Spatial light modulator (HPDLC)										
signal-to-noise ratio										
	>100:1		>200:1		>500:1					
diffraction efficiency										
	>60%		>80%		~100%					
aperture										
Refresh rate										
Angular separation	~ms		<ms		<ms					
brightness										

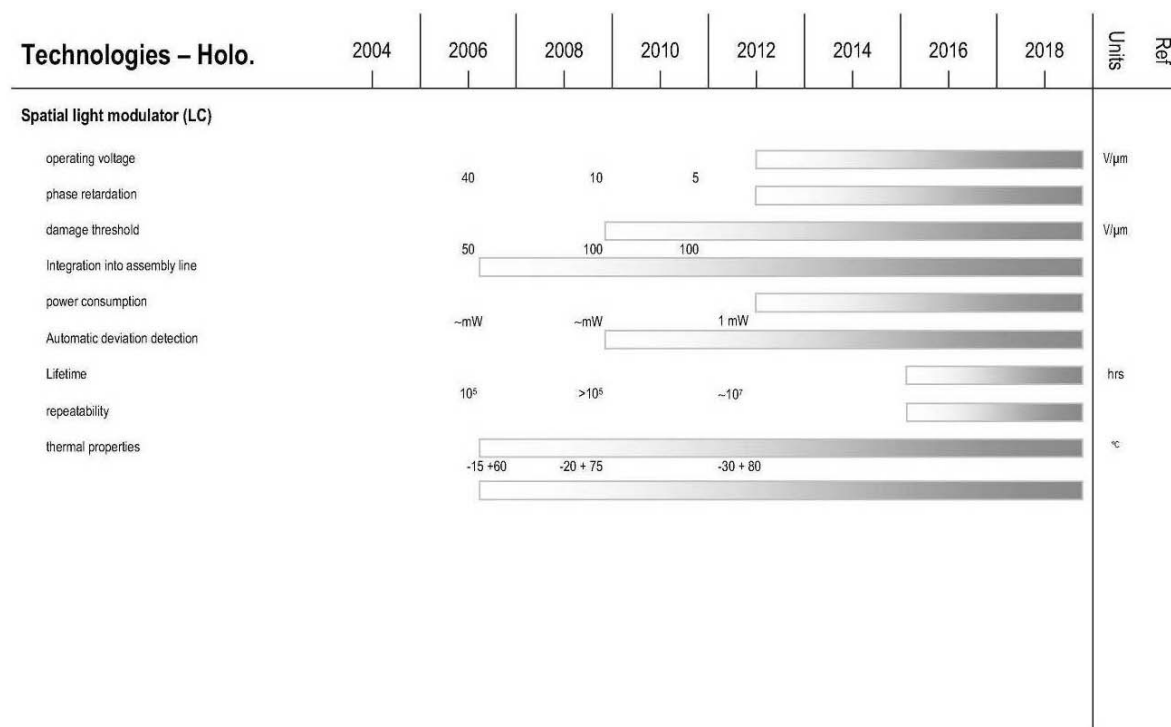

- i. The technology required for this is simple and well established. The principal enabling technologies are LCDs, parallax barriers, lenticular screens, prismatic screens and liquid crystal layers for 2D/3D switching. Possibly the most significant change in the near future will be the replacement of LCD displays with OLEDs.
- ii. This technology is also well established and is currently commercially available. Two versions of this are the *SeeReal* and *HHI* displays that employ head position trackers and direct-view LCDs. The *HHI* display enables a greater degree of freedom of movement than the *SeeReal* display, but requires the LCD to be positioned in the portrait orientation. This will require an LCD that has its RGB sub-pixels running in the horizontal direction. Another approach is to use a view-directing lenticular screen with a pitch that allows an LCD with vertically aligned sub-pixels to be used.
- iii. A promising approach for a 3DTV display is the *DMU/HHI* head tracking display (MUTED project). The display utilises directional backlit sources to project the left and right views on a direct-view LCD into multiple users' eyes. This technology reduces the need for image data to a minimum and provides high spatial image resolution for each viewer. One possibility is to use an RGB laser source in conjunction with a LCOS computer generated hologram (CGH). It is unlikely that a suitable laser source will be developed within the lifetime of the project but the feasibility of this approach will be assessed.
- iv. Another approach to a multi-user head tracked display utilises a scanned laser in conjunction with a specially designed screen, MEMS scanner, light valve and spatial light modulator. The requirements of the laser include RGB capability with > 50 mW per channel; compact; robust and efficient design; low noise (< 1% rms); good power stability (< $\pm 2\%$); high pointing stability (< $\pm 2 \mu\text{m/K}$, < $\pm 6 \mu\text{rad/K}$); micro-optics beam combiner; beam parameters ($M^2 < 1.2$, telescope); and fast intensity modulation (> 20 MHz).
- v. A possible outcome of using scanned lasers and head tracking is a display offering continuous motion parallax (MP) to several (N) viewers by providing 2N views. The images are defined by the viewers' eye positions. This requires faster light valves and SLMs that can display the greater number of images.
- vi. This approach uses video projection technology for large-screen 3D presentation (display sizes of 100 inches and more). Multiple high-resolution 3D images are projected simultaneously with a novel multi-view video projector onto a specially coated direction selective screen. Multiple viewers perceive the 3D effect without the need of head tracking. The multiple views allow individual changes in perspective when the users move (individual look-around effect). This

technology requires a complex projection unit offering a short-term solution suited for cinema applications and advanced large screen 3DTV sets.

- vii. Multiple image displays using LC panels provide a simple solution for 3DTV. They are relatively simple to construct but suffer from decreasing spatial resolution with increasing number of views, image flipping between adjacent views, and limited depth. These problems can be solved by using LC panels having huge spatial resolution. The huge number of pixels leads to a very small pixel size and very small structures of image separating components (e.g. parallax barriers or micro lens plates). The feasibility of component realisations and theoretical limits must be investigated.
- viii. A display panel with high resolution in the horizontal direction can be used to provide a multiview display with the addition of a lenticular screen. OLED displays with a stripe width of 1 μm are under development. This would enable the presentation of a large number of views – possibly sufficient to give the appearance of smooth motion parallax. There are many challenges in fabrication and pixel addressing.
- ix. Different perspectives are provided by moving a vertical slit across the screen. An image is viewed through this slit, which changes in accordance with the slit position. The slit consists of a series of vertical strips of ferroelectric liquid crystal material that are sequentially switched to the transmission mode in order to produce the moving ‘slit’. The information on the image screen needs a rapid frame rate in order to avoid image artefacts such as ‘tearing’ of the image. A projector incorporating a two-dimensional light valve (LV) produces the image. Currently a digital micromirror device (DMD) is used. This approach is being taken by the Hungarian company *Holografika*. Very little information is available, but it is believed to use an HOE screen, a DMD and possibly LED arrays. The display produces effectively a large number of views and therefore, a large amount of information is displayed. Irrespective of operation, the technologies mentioned facilitate the display of large amounts of information, and hence will be suitable for other display configurations.
- x. Volumetric displays have two forms: virtual image or real image. In virtual image displays, each voxel appears as a virtual image in either a moveable mirror or lens. Real image displays produce a series of sequential sections of the image on a moving screen. The image is either be projected or emitted (e.g. from an LED array). Due to the image transparency, and to the use of moving parts, these displays are unlikely to be suitable for anything but small niche markets. Improvements in this approach could be achieved by, for example, improved variable focus mirror assemblies, faster light valves, improved moving screen assemblies and high-density LED arrays. Volumetric displays without moving parts are more likely to provide a viable future alternative. These are currently commercially available in the form of a series of stacked LCD screens where one screen at a time switches from the transparent to the translucent state, in this way replicating the action of a moving screen. Other approaches include the use of light guides to guide the light to each voxel position and intersecting infrared lasers that excite a solid rare earth-doped screen.
- xi. Future 3DTV technology will be highly interactive and non-intrusive. Hence, remote sensing and tracking techniques are required. Existing tracking technologies have to be improved. Essential improvements include fully automatic operation (initialisation and tracking), robustness with regard to changing ambient light conditions, low latency and high measurement rates, as well as precise measurements along the optical axes of the cameras. Moreover, novel human interface technologies such as hand position sensing and gesture recognition devices enhance the usability and attractiveness of 3D displays.

Task 2: Roadmap for Autostereo

A roadmap for the development of an autostereoscopic display

Participants: DMU, FhG-HHI, FogS, Plzen

Author: P. Surman

Summary

The Roadmap covers all types of 3D display that do not require the wearing of any attachments to the head but also are not purely holographic. The time-scale of the roadmap is ten years as it is unrealistic to look ahead further than this due to the inability to predict with any accuracy the future enabling technologies beyond that. In addition, this timescale fits in well with the possible introduction of a 3D television system since enabling technologies to support 3D displays are developing rapidly.

Until recently there has been no absolute consensus, even amongst 3D researchers, that consumers will prefer a 3D display over, say, large high-definition displays. However, the mood seems to be changing and it is becoming more widely accepted that 3D digital cinema will be the next big thing and that this will drive the demand for 3D television in the home. Although there is a general assumption that viewers will find the wearing of special glasses unacceptable, this seems to be based on anecdotal evidence only. However, for the purposes of the roadmap, it is assumed that the display will be glasses free (autostereoscopic).

Autostereoscopic Display Types

In order to determine 3D requirements it is useful to summarise the capabilities of the possible approaches. The basic generic types of 3D display are: binocular, multiple-image, volumetric and holographic. The definitions of the non-holographic types are as follows:

- **Binocular:** A binocular display is one where only two separate images are presented to each eye of the viewer/s. The viewing regions where the images can be observed may occupy fixed positions, or they may move to follow the viewer/s head position/s under the control of a head tracker.
- **Multiple-image:** In multiple-image displays either a series of discrete images is presented across the viewing field or the light radiating from each point on the screen varies with direction.
- **Volumetric:** A volumetric display presents a 3D image within a volume of space, where the space may be either real or virtual.

Binocular: The simplest type of autostereoscopic display produces regions, referred to as exit pupils, that remain in fixed positions in the viewing field where a stereo pair can be observed. There may be either a single pair of exit pupils or a series of them where left and right images are seen alternately across the viewing field. The Sharp laptop [1] is an example of this type of display. These have the benefit of having simple construction but have the disadvantage that users have restricted movement. This can be overcome with the use of head position tracking in order to enable the exit pupil positions to follow the users' head positions. Single user head tracked displays have been produced by Fraunhofer HHI [2] and SeeReal [3]. Multi-user head tracked versions have been developed in the EU ATTEST [4] and MUTED [5] projects.

Where a single stereo pair is presented to a single viewer it is possible to present motion parallax, the 'look-around' capability, by rendering the images in accordance with the viewer's head position so that true perspective views are seen. The MUTED display shows the same image pair to every viewer so that it is not possible for all viewers to see motion parallax. In the HELIUM3D project a laser-based display is under development where a fast field rate can allow a large number of images to be shown sequentially so that every viewer's eye perceives a different image therefore making the presentation of motion parallax possible [6]. This also can provide other interesting '3D+' modes of operation; for example images selected by viewers or images targeted to particular user.

All binocular displays have the disadvantage accommodation/convergence rivalry where the users' eyes focus at the screen but invariably converge at a different distance. This can cause effects on the user, for example headaches and nausea and can be minimised by generally keeping the disparity low with high disparities when required for special effect. Effects of the lack of motion parallax include 'false-rotation' where the image apparently moves laterally as the viewer moves and geometrical apparent distance distortions.

Multiple-image: A large class of autostereoscopic displays can be usefully termed 'multiple-image' and may be of two types: multi-view and multi-beam. A multiple-view display is one where two or more different two-dimensional views are presented across the viewing field. These may be multi-view with between three and several tens of images, through to holoform with more than this. A holoform display is defined as a multi-view display where the number of images presented is sufficiently large to give the appearance of continuous motion parallax. In multi-beam displays the light radiating from any point on the screen varies with direction in order to reconstruct the 3D surface away from the plane of the screen.

Multi-view: The distinction between multi-view and holoform is based on the work of several researchers who have determined the criteria for the appearance of smooth motion parallax and for the accommodation and convergence of the eyes to be the same. A research group in the 3D project at the Telecommunications Advancement Organisation in Japan have determined that each pupil must receive two or more parallax images in order for the eye to focus at the same distance as the convergence [7]. FhG-HHI has determined that typically 20 views per inter-ocular distance are required for the appearance of smooth motion parallax [8]. This latter figure is supported by St Hilaire of MIT [9].

Multi-beam: There are various means of providing a multi-beam display. The Holografika display [10] uses an array of optical modules in conjunction with side mirrors behind a holographic screen to produce the light beams. A similar method is adopted by QinetiQ who employ an array of 40 projectors [11]. Another approach is to use a dynamic parallax barrier where a vertical slit effectively moves rapidly across a ferroelectric panel that is located in front of a screen. The information on this screen updates rapidly with the use of a fast DMD-based projector.

Volumetric: Although the current generation of volumetric displays are currently generally unsuitable for many 3D applications due to image transparency, it is possible that in the future displays with opaque could be developed. The advantage

volumetric displays have over multiple view displays is that each voxel is only displayed once – as opposed to N times for a multi-view display with N views. This gives them a greater efficacy in terms of display usage. They also do not give accommodation/convergence rivalry and provide motion parallax in both the horizontal and vertical directions.

A summary of the advantages and disadvantages of each basic generic type of autostereoscopic display is given in Table T2-1

Possible Display Types

Although other autostereoscopic techniques may emerge over the next decade, currently the most likely methods to provide a display that will fill this window of opportunity are given in Figure T2-1 where the approximate timescales of these are shown in relation to past and current EU projects that include 3D TV NoE members. Each of the anticipated methods is considered below.

(a) Holografika Multi-beam Display: The display developed in the EU Holografika project is in the category of ‘multi-beam’ as virtual voxels are created by intersecting beams that may be located either in front of or behind the screen or in the plane of the screen itself. Examination of the geometry reveals that the further the voxels are located from the screen the more elongated they become. The current angular resolution of 0.8° limits the depth of field of the image and the display would benefit from advances in FLCOS micro-displays with very fast switching speeds in single panel configuration, solid-state technology in the illumination based on high brightness LED-chips, special micro-optical components and plastic aspheric and diffractive optical elements.

(b) HELIUM3D type Display incorporating Diffractive Light Valve: The display under development in the EU HELIUM3D project employs an RGB laser source incorporated into a head tracked 3D display that does not require an LCD. Images are formed on a two-dimensional LCOS device that is illuminated by a scanned laser beam. A more elegant solution could possibly be provided by a linear diffractive light valve whose design is more suited to operation in this display configuration. Such devices have been developed, specifically for digital cinema, but their adoption has been delayed by the lack of a suitable RGB laser. It is possible that the HELIUM3D approach could provide an application for these devices and they may be made available for research purposes by the latter part of 2008. It is envisaged that a prototype based on this technology could be developed by 2010 and be progressed to a commercially available product by 2013.

Display Type				No. of Viewers	Viewer movement	Motion parallax	Acc/con v rivalry	Image transparency
Binocular	Non head tracked			Single	Very limited	No	Yes	No
	Head tracked	Single user		Single	Adequate	Possible	Yes	No
		Multiple user	MUTED	Multiple	Large	No	Yes	No
			HELIUM3 D	Multiple	Large	Possible	Yes	No
Multiple-image	Multi-view			Multiple	Adequate	Yes	No	No
	Holoform			Multiple	Large	Yes	No	No
	Multi-beam			Multiple	Large	Yes	No	No
Volumetric	Conventional	Real image		Multiple	Very large	Yes	No	Generally
		Virtual image		Multiple	Large	Yes	No	Generally
	Quasi-volumetric			Multiple	Large	Yes	No	No

Table T2-1 Performance Advantages and Disadvantages of Generic Types

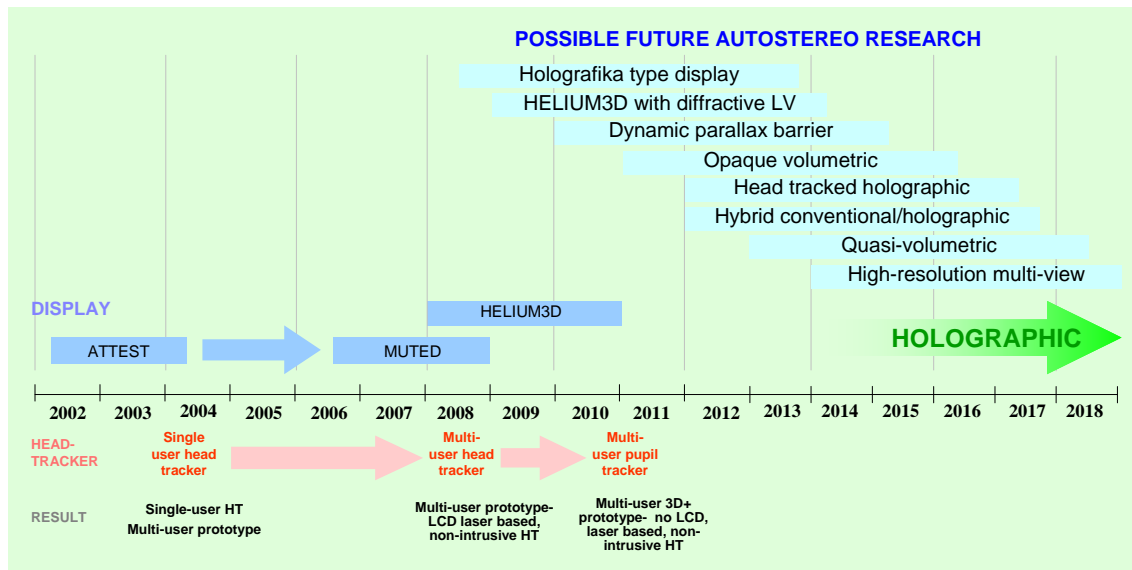

Figure T2-1: Future Auto-stereoscopic Technologies

(c) Dynamic Parallax Barrier Multi-beam Display: Fraunhofer PST is a German incorporated association that provides support to the development of advanced technologies and their commercialisation. They have supported the development of a stereoscopic display device based on the time division technique; this lies within the multi-beam category. A system using the Digital Micromirror Device (DMD) by Texas Instruments and F-LCOS (ferroelectric liquid crystal on silicon) dynamic parallax barrier manufactured by Forth Dimension Technologies has been demonstrated. This display gives motion parallax but suffers from the disadvantages of having a large proportion of its light being blocked by the barrier and the restricted speed of the DMD for this application causing image break-up. A very similar system has been developed by Setred [12] in conjunction with Cambridge University [13]. A faster projector must be developed in order to this approach to be viable.

(d) Opaque Volumetric Display: Conventional volumetric displays where 3D images are built up from 2D 'slices' of the image, usually suffer from the drawback that displayed surfaces are 'transparent'. Although the display hardware for volumetric displays tends to be complex, they have the potential to provide 3D images in the most effective manner with regard to the amount of information that has to be displayed, as each image voxel is only shown once (unlike, for example, an N-view multi-view display where each 'voxel' is displayed N times). However, there are now some proposed methods where this limitation can be overcome.

(e) Head Tracked Holographic Display: Holography has the potential to provide the most natural representation of a real-world scene, but at the expense of providing images over large unused regions of the viewing field where viewer's eyes are not present. Therefore, a strategy to present images only in the regions where viewers' eyes are present appears to be a logical way forward. This approach has been proposed by the German company SeeReal who intend to use a relatively low-resolution display (in comparison to that required for conventional holography) in conjunction with a high-accuracy head tracker [14]. By making holograms only visible in regions around 10 mm across, referred to as 'windows', it is possible to

reduce the resolution of the screen from around that of a wavelength of light to something in the order of 25 μm . Although this is a good idea in principle, there are various practical difficulties that must be overcome. A display with a 25 μm pitch could possibly be available in the near future; however its speed requirement would be an issue. If, say, four users are to be served then the field rate will need to be eight times faster (four viewers multiplied by two eyes each) for monochrome. For colour the rate will have to be three times higher, giving an overall increase in field rate a factor of 24 times; this would therefore require a field rate in the order of 1500 Hz. A device capable of running at that speed and also providing grey scale is unlikely to be available in the very near future. Given the small size of the windows the multi-user head tracker will require a high specification in terms of latency and accuracy.

(f) Hybrid Conventional/Holographic Display: The MUTED, SeeReal and HELIUM3D displays are examples of hybrid conventional/holographic systems. Hybrid systems are likely to become more viable with the introduction of new enabling technologies. One driver for this could be the introduction of laser-based television by Mitsubishi predicted for late 2008 [15]. As the illumination source of any hybrid system is most likely to be an RGB laser (although also possibly LEDs may be suitable) this could help shift display technology away from its current dominance by LCDs and encourage technology and safety development in laser-based displays.

(g) Quasi-volumetric Display: A variant on volumetric displays would be 'quasi-volumetric' where the problems of image surface transparency and the presentation of non-specular light emission from image voxels can be overcome. This becomes possible when lasers are not employed for necessarily their high coherence properties but for their ability to produce low etendue (source size multiplied by solid angle emitted) beams. Low etendue enables the necessary high degree of light control required. The strategy of employing the 'Ray Space' transformation in the reverse manner to its normal use for compression of 3D images has the potential to overcome the redundancy issues associated with multiple-image displays where one 'voxel' is displayed many times. Suitable technology to implement this approach, namely fast light valves, fast MEMS devices and advanced holographic optical elements (HOEs) are currently not available and are not likely to be obtainable within the next five years.

(h) High Resolution Multi-view Displays: Multi-view displays are currently restricted by display resolution. The 9-view 'Wow' display from Philips [16] uses a slanted lenticular screen in front of an LCD in order to reduce the resolution by a factor of three in both the horizontal and vertical directions. The depth of field of the displayed image is limited as the visible regions for each view need to overlap in order to provide a smooth transition between views. More views provide greater depth of field and Philips are developing a 15-view version but is not yet commercially available. Higher resolution displays will provide the evolution of multi-view displays into better performing versions.

Conclusions

It is unavoidable that there is an increase in the amount of information which needs to be displayed in order to present 3D. This increase is achievable in three ways:

- Increase the speed/resolution of the display devices

- Employ head tracking to present images only where eyes are present
- Display images in a way that requires the least redundancy

Increasing speed and resolution of the display is the option that methods (a), (c) and (h) depend on in order to progress. Holografika have stated that the equivalent of a 100 megapixel display would be the optimum for their system - this is rather high by today's standards and may be for some years to come in the future. The use of very high resolution OLEDs for a multi-view display has been investigated by the University of Kassel [17]. A small demonstrator has been built with a horizontal pixel pitch of 2.5 μm enabling 112 views over 30°. No forecasts are available for the timescale for a large size high resolution OLED panel to become available, but for reference, the forecast for the market for OLED TVs is estimated to be around \$1.4 billion by 2013 [18].

Although the head tracking displays (b) and (e) are complex, they do enable the display of images intended for particular eyes only. A hologram for example will enable an image to be seen over large regions where no eyes are actually located, therefore requiring the need to display large amounts of redundant information.

As mentioned previously volumetric displays (d) do not require redundant information to be displayed, however, their complexity and image transparency issues may be difficult to address in time for a mainstream product to be available over the next decade. Quasi-volumetric methods (g), where virtual horizontal image planes are produced, could potentially provide the means of overcoming the high information requirement of types (a), (c) and (h) where a single 'voxel' is fragmented either spatially or temporally in the display. Quasi-volumetric displays would not have the ability to exhibit vertical motion parallax.

Hybrid displays (f) are mentioned as a separate research area but in reality it is likely that a high proportion of all research and products in the future will incorporate both techniques to some extent. This could be the situation for the foreseeable future so that there may never be any sudden transition from 'autostereoscopic' to 'holographic'.

References

1. http://www.sle.sharp.co.uk/research/optical_imaging/3d_research.php
2. K. Hopf, F. Chojecki, F. Neumann, "Novel Autostereoscopic Single-User Displays with User Interaction", Proceedings of the SPIE Three-dimensional TV, Video, and Display V, Volume 6392, Boston MA, (2006)
3. P. Surman, I. Sexton, R. Bates., K. C. Yow. and W. K. Lee, "The Construction and Performance of a Multiviewer 3D Television Display", Journal of the SID, Vol. 13, Issue 4, pp 329-334, (2005)
4. <http://www.hitech-projects.com/euprojects/attest/summary.htm>
5. <http://www.muted3d.eu/>
6. <http://www.hhi.fraunhofer.de/en/departments/im/research-projects/helium3d.html>
7. Y. Kajiki, H. Yoshikawa and T. Honda, "Three-Dimensional Display with Focused Light Array" SPIE Proceedings, "Practical Holography X", Vol.2652, pp 106-116. (1996)
8. S. Pastoor, "Human Factors of 3DTV: An overview of Current research at Heinrich-Hertz-Institut Berlin", IEE Colloquium "Stereoscopic Television" Digest No. 1992/173, p11/3. (1992)
9. P. St Hilaire, "Modulation Transfer Function of Holographic Stereo-grams" Paper from Internet – originally published in "Applications of Optical Holography", 1995 SPIE Proceedings. (1995)

10. T. Baloch, "Method and Apparatus for Displaying Three-dimensional Images", United States Patent No. 6,201,565 B1, (2001)
11. http://www.qinetiq.com/home/newsroom/news_releases_homepage/2004/3rd_quarter/autostereo_3d.html
12. <http://www.setred.com/>
13. C. Moller and A. R. L. Travis, "Flat Panel Time Multiplexed Autostereoscopic Display Using an Optical Wedge Waveguide", Proceedings of The 11th International Display Workshops, Niigata, Japan, pp1443-1446. (2004)
14. A. Schwerdtner, "Video Hologram and Device for Reconstructing Video Holograms using a Fresnel Transform", Unites States Patent 20060238843, (2007)
15. <http://www.itwire.com/content/view/16047/1103/>
16. <http://www.business-sites.philips.com/3dsolutions/news/article-15169.html>
17. www.uni-kassel.de/fb16/ipm/dt/de/forschung-lehre/3d_oled_demonstratot_sid_06_kent_oh.pdf
18. <http://www.isuppli.com/news/default.asp?id=8688>

Task 3: A Roadmap for Applications**A roadmap for the development of a set of representative applications**

Participants: Bilkent, UNIABDN, BIAS, DMU, CLOSPI-BAS, FogS, ITI-CERTH, TUT, KU, METU, Momentum, Plzen, Yogurt

Author: T. Reyhan

This roadmap is an update of that presented in WP12-TR2.

3D representation of visual data has entered into our daily lives and we use such techniques in CAD systems, medical representations, consumer advertisements, education and military to name but a few. Historically, many 3D displays and projectors utilise some kind of glasses or goggles employing polarisation or colour differences. The 3D representations projected on 2D displays are very useful and are gaining widespread acceptance, but the same kind of public acceptance has never been enjoyed by 3D display and projection systems employing glasses. The only exception could be 3D cinema, which is gathering momentum over the last few years, thanks to the high definition projectors that make them attractive.

It is not easy to analyse the factors inhibiting the public acceptance of 3D projection systems in the framework of this report. Nevertheless, it is true that one of the major obstacles preventing this acceptance could be the necessity of wearing glasses. The emerging 3DTV technologies and their potential applications concentrate on techniques that eliminate the need for glasses and provide multiple viewers with the comfort of unrestricted visualisation from (hopefully) a large viewing angle.

There are experimental systems that can provide unrestricted viewing of 3D projections based upon a variety of principles ranging from stereoscopic projectors to holographic displays. One would expect a favourable response from the public as these are more realistic projectors of the native environment (3D). However, there is some market resistance to their take-up and companies are very hesitant to incorporate them into their products. The probable causes that might slow down the introduction of 3DTV and related technologies to the public can be summarised as follows:

- 3D projectors or displays need to present a greater number of pixels (voxels) than needed for a 2D image. Therefore, with the available display and projection technologies, they always have less resolution than the competing 3D images projected on a high-resolution 2D display. The achievable resolution of the 3D display must substantially increase to be acceptable,
- The amount of data to be processed and transmitted are again a many times greater than their 2D counterpart,
- The cost of 3D systems are going to be substantially higher than 2D for the foreseeable future,
- Public acceptance always depends on mass production, which is itself a precondition to lower cost.

The future of potential applications of 3DTV depends upon the factors cited above and more. 3DTV techniques and the underlying support technologies, are developing rapidly. It also true that, some applications of 3DTV, such as in the military and medical fields, are likely to make earlier appearances in the market because of cost implications. Other developments will take some more time to reach prominence. In order to shed light on the future of potential applications, the following roadmap helps to illustrate the developments in this field.

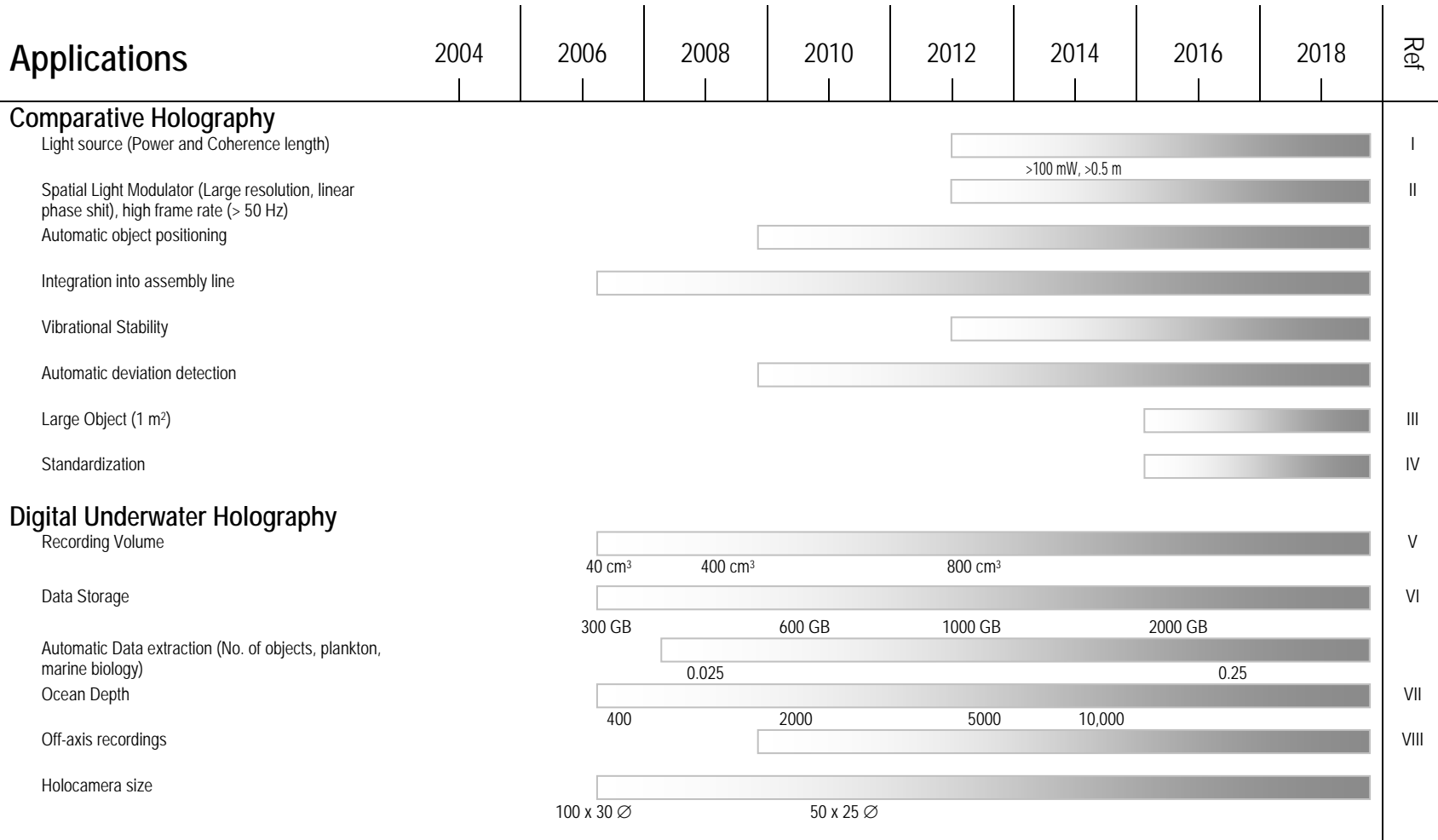

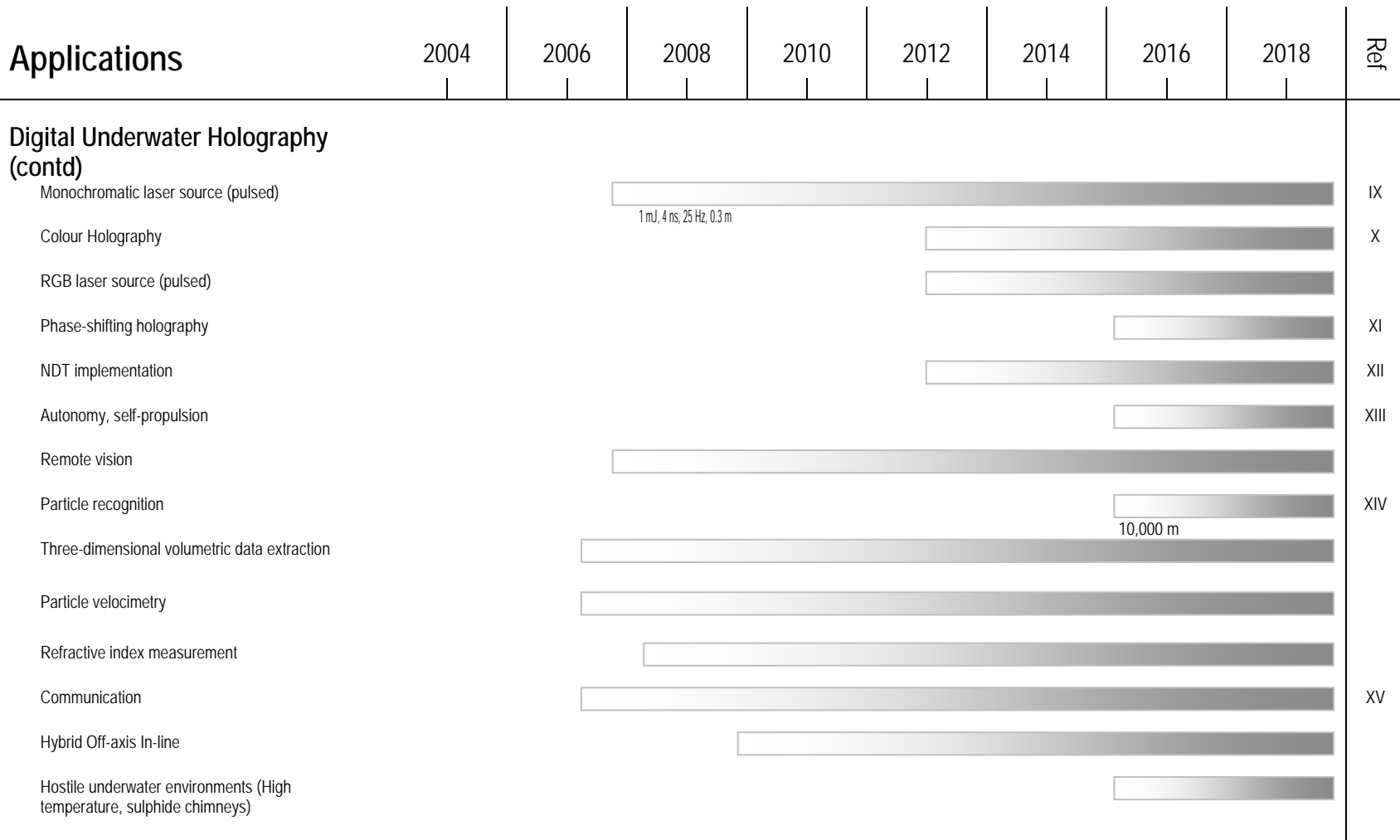

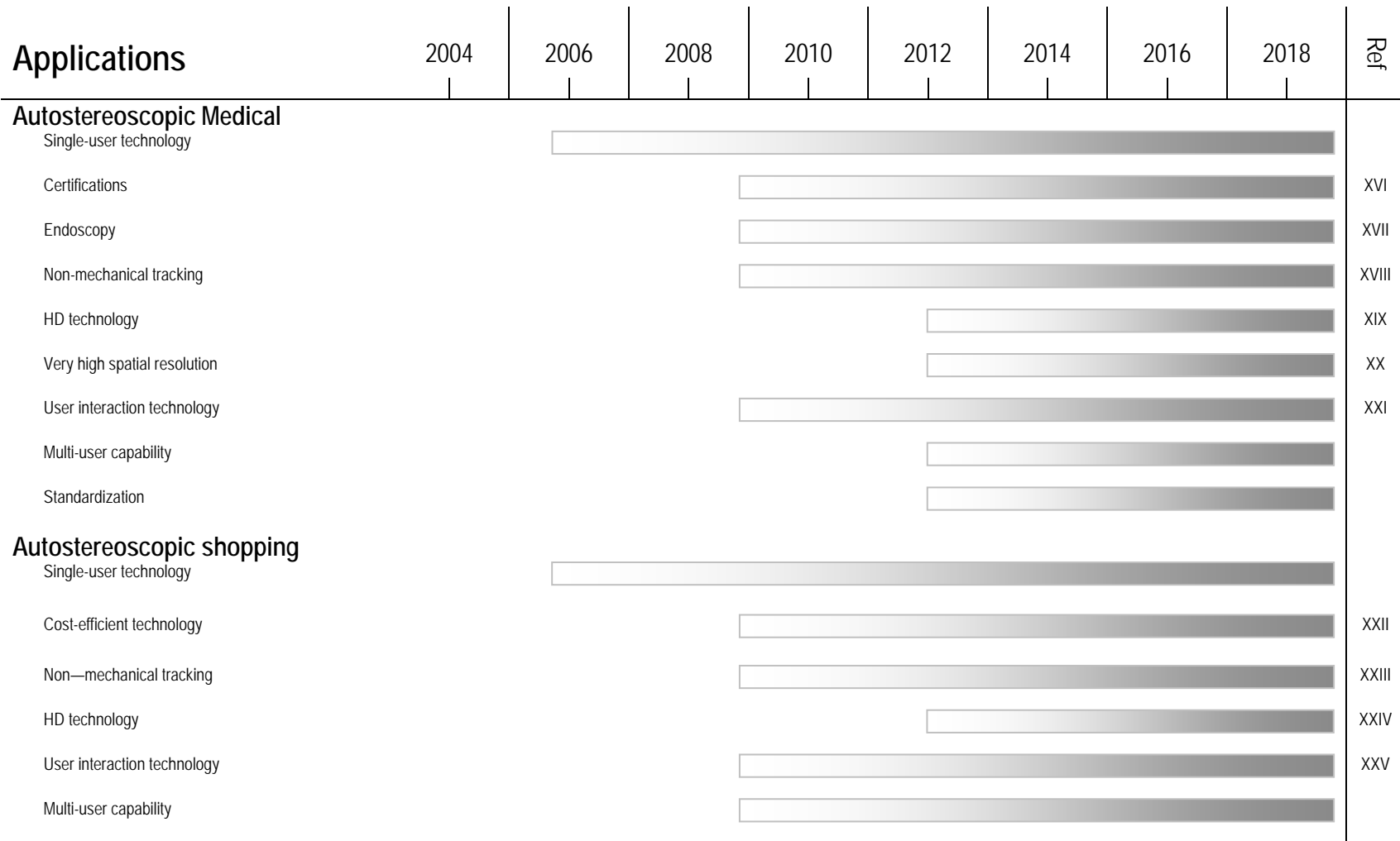

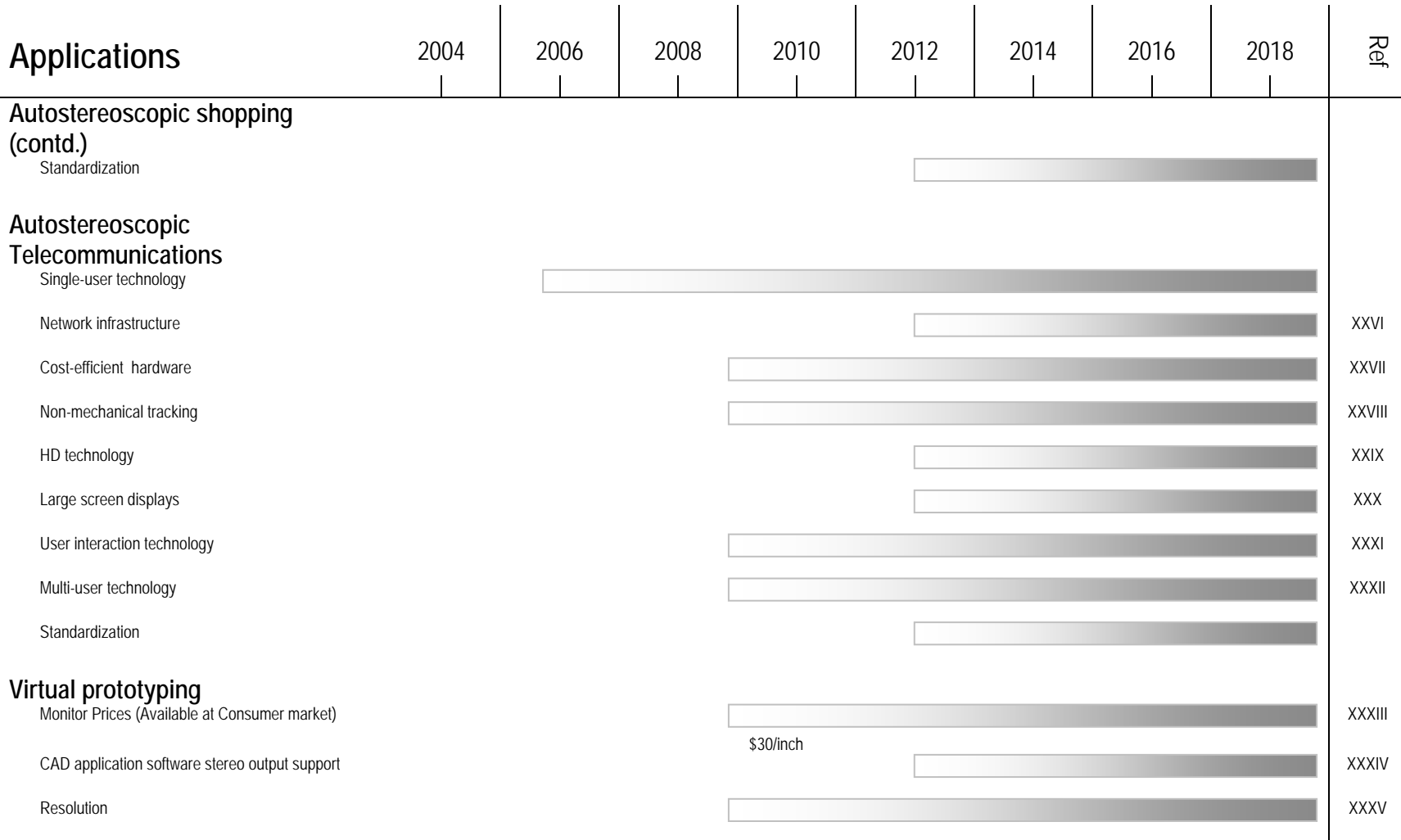

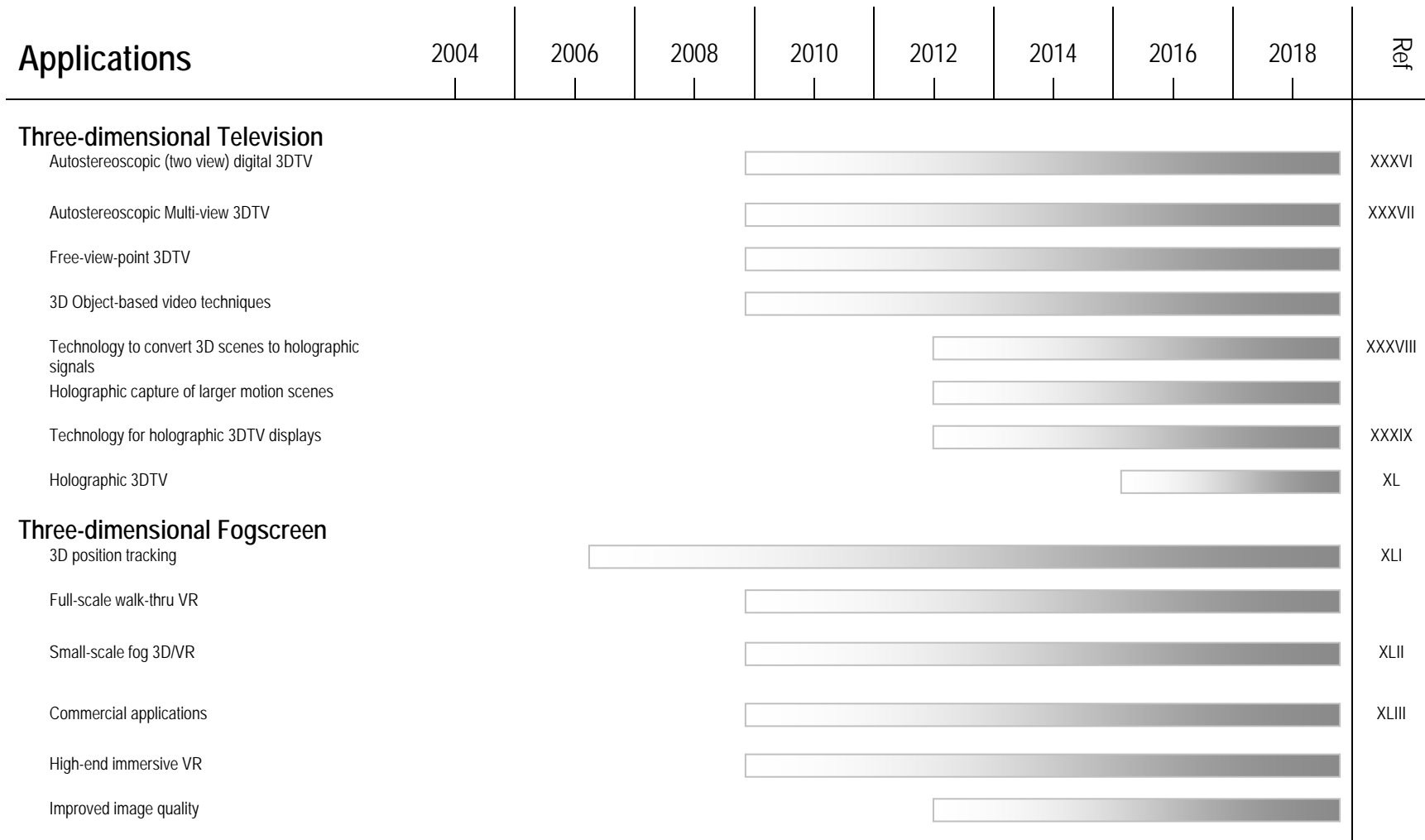

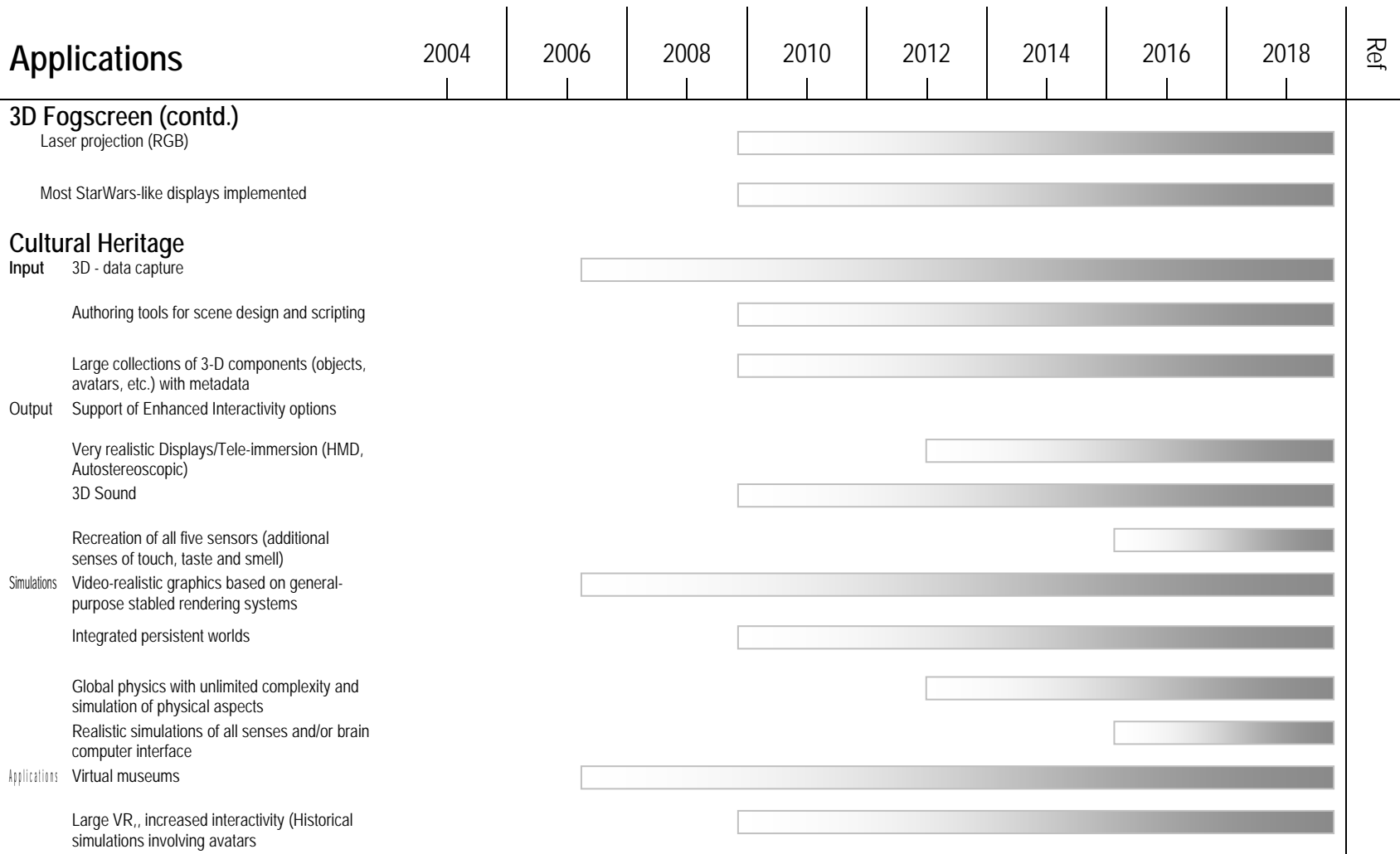

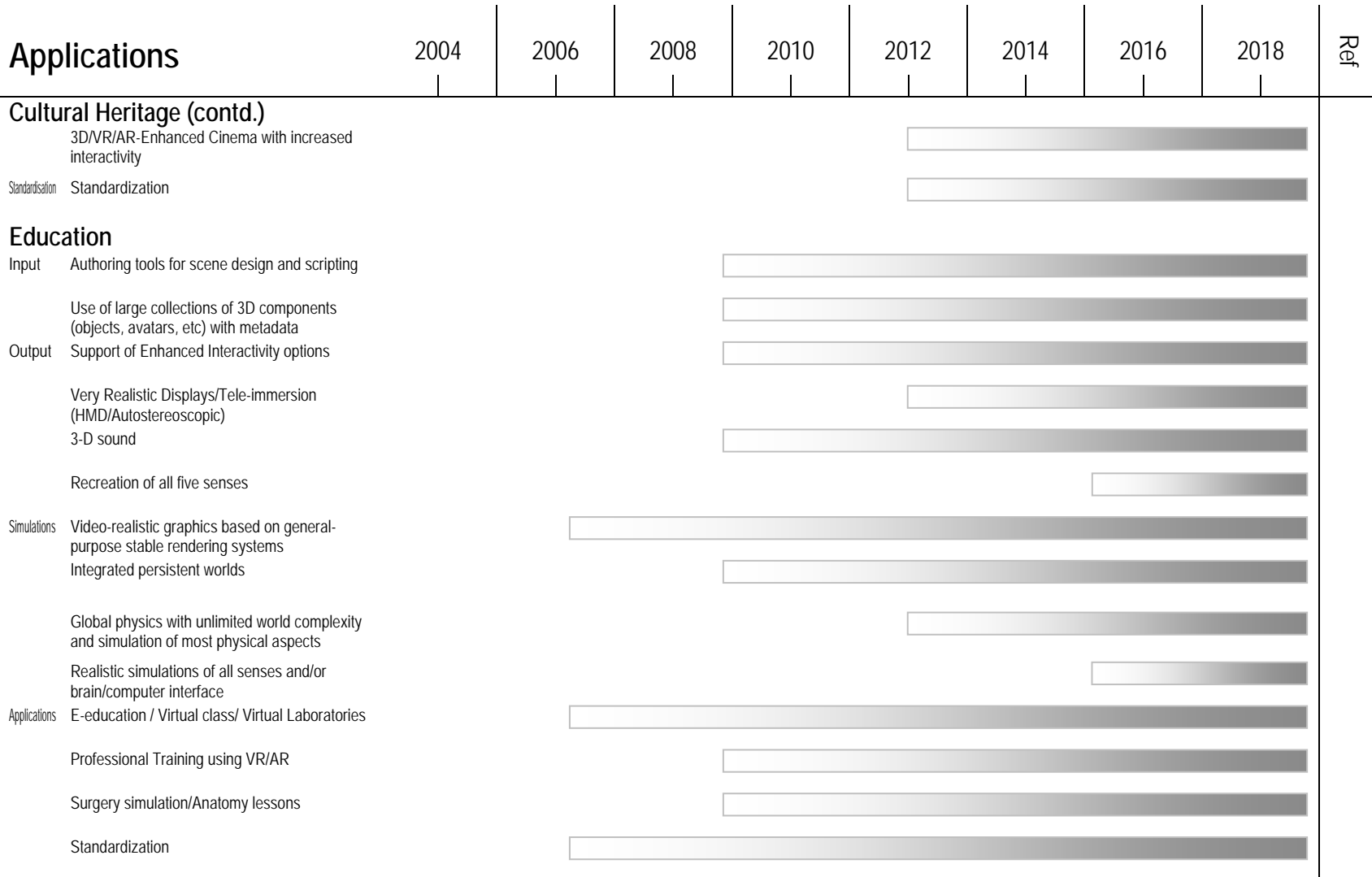

Reference Notes to Roadmaps

- I Requirements: compactness, $2-\lambda$ (tuneable), optical power > 100 mW, coherence length (> 0.5 m)
- II High resolution (> 3 k x 2 k pixels), linear full phase shift, high repetition rate (> 50 Hz), minimum optical losses, high damage threshold, low pixel-pixel cross talk
- III Existing objects are around 5 cm²
- IV Current standardisation emphasises tactile systems, for optical systems new standards needed
- V SOA for subsea in-line holograms is 40 cm³ volume. Many factors limit large volume recovery of dynamic data: e.g. amount of data captured from dynamic holograms. For a high-resolution sensor (e.g. IBIS4-6600) can capture full-frame (3 k x 2 k pixel count) digital in-line holograms at 5 Hz. Frame rate increased by reducing pixel count, at loss of total imaging volume. Therefore, a limiting factor is speed of capture. In subsea holography of marine plankton, 25 Hz frame rate is adequate.
- VI Next consideration is data storage. Capturing at 25 Hz, for 3 k x 2 k pixel count and 10 bit grayscale resolution, requires ≈ 300 GB storage. For autonomous recording, if storage is on the camera vehicle space and power requirements become an issue of the hard disk drive and computer. High power pulsed laser needed for scene illumination. Limitations relate to capture time on a moving vehicle. Required lasers are physically large; with large power source and often cooling. Total potential recording volume will increase in tandem with improved pixel count and pitch of CCD/CMOS. Limitations of data storage and post and pre-processing in terms of numerical reconstruction and data storage will limit the technology.
- VII Classical photo-holocameras have not been deployed much below 200 m. Current digital subsea holocameras are designed to 2 km, (but only deployed to 400 m so far). Development of deep water (> 11 km) subsea holocameras is restricted by considerations of pressure housing, battery power, temperature, data storage, remote/autonomous operation difficulties.
- VIII Digital subsea holography utilises in-line geometry. With reduced pixel dimensions, useable reference/object beam angle increases - this helps to negate in-line problems like the twin-image. Off-axis geometry better for large-volumes/opaque targets and yields surface structure information.
- IX Currently for vibration stability, pulsed lasers are synchronized to the capture device. The laser must be of a suitable size and compactness for the housing and the power consumption must be suited to autonomy. The parameters specified are energy per pulse, pulse width, pulse rate and coherence length. As the required capture volume increases the required energy per pulse increases as does the coherence length (off-axis holography).
- X The specification for a colour off-axis underwater holographic system is challenging. Requirements include piezo-electric mirrors and a pulsed RGB laser source. The specification per pulse is similar to that of the monochromatic design.
- XI Phase-shifting holography will produce improved information retrieval from the scene; however, the complexity of design greatly increases.
- XII This is a good potential spin-off technology for underwater holography. Inspection of underwater pipes for damage or the underside of ships, are potential applications here. See "XV" above.
- XIII Existing vehicles are not fully autonomous. This facility would increase the versatility of underwater exploration.
- XIV So far work has focused on automatic data extraction of objects from underwater scene have recognition and characterisation of these objects must also be achieved.
- XV Ideally, untethered deployment of holographic cameras could be implemented. However, this is difficult to achieve for the bandwidth requirements of holography.
- XVI Usage in hospitals requires specific certifications.
- XVII Integration and test of endoscopic 3D camera systems.
- XVIII First single-user 3D displays suitable for medical applications use mechanical tracking. Non-mechanical, robust and cost-effective technology is likely to replace this.
- XIX High density/high definition technology suitable for coloured images in high spatial resolution
- XX Very high spatial resolution suitable for presenting 3D radiographic images
- XXI Implementation of novel user interaction devices replacing mouse and/or keyboard
- XXII Consumer market demands for cost-efficient terminal equipment
- XXIII First single-user 3D displays suitable for shopping applications use mechanical tracking. Non-mechanical, robust and cost-effective technology is likely to replace this.
- XXIV High density/high definition technology suitable for coloured images in high spatial resolution
- XXV Implementation of novel, user-interactive devices will replace mouse and/or keyboard.
- XXVI Realization of area-wide fast network infrastructure suitable for 3D telephony and conferencing
- XXVII Consumer market demands for cost-efficient terminal equipment

- XXVIII First single-user 3D displays suitable for telecommunications use mechanical tracking. Non-mechanical, robust and cost-effective technology is likely to replace this.
- XXIX High density/high definition technology suitable for coloured images in high spatial resolution
- XXX 3D video conferencing services with natural size presentation require large screen displays
- XXXI Implementation of novel user interaction devices replacing mouse and/or keyboard
- XXXII Consumer market demands for cost-efficient terminal equipment
- XXXIII Autostereoscopic display device prices are significantly decreasing which indicates that in the next few years these devices will be available on the consumer market. *Dimension Technologies Inc.* 18 inch monitor prices: 1999=\$13,949; 2001=\$6,999; 2006=\$3,695 (19 inch price); Sharp 15 inch autostereoscopic monitor price; 2006=\$449
- XXXIV Currently it is possible to obtain stereo output from major Virtual Prototyping tools such as *3ds Max*, *GOCad*, *OrthoCAD*, *SolidWorks* via third party software (*VR Max*, *TriDef* etc.). It is expected that these companies will provide built-in stereo output support not later than 2012.
- XXXV Because of technology limitations, autostereoscopic monitors currently offer lower resolution. The CAD industry mostly demands high-resolution. Although 2D/3D switchable displays exist, they still offer low resolution in 3D mode. Existence of a few high-end products (e.g. *Iris 3D*) that offer high resolution in autostereoscopic mode shows that this problem will be overcome in the next few years.
- XXXVI Basic infrastructure will be in place as digital standard and high-definition TV will be widely in use. The 2006 Digital Cinema Initiatives (DCI) specifications as finalized by SMPTE will also pave the way to many 3D stereo commercial movies. The digital broadcast of these 3D movies via digital TV infrastructure will be a common practice.
- XXXVII Standardization activities within ISO-MPEG4-3DAV are entering a mature state in 2006. This may lead to wide-spread commercial multi-view video production and its display for “multi-view and free-point-of-view 3DTV”.
- XXXVIII Current CCD cameras are limited due to their small array sizes.
- XXXIX Currently available SLMs have very small array sizes. Many alternative technologies and display methods must be developed and tested
- XL Besides having the currently available SLMs with very small array sizes and having to wait for many alternative technologies and display methods to be developed and tested, holographic 3DTV requires large processing power both in hardware and software.
- XLI First implemented in 2005 using *WorldViz PPT* tracker. Tracking will improve in many ways in the future.
- XLII 1 meter wide (50” diagonal) screens or below. Also for broadcasted 3DTV.
- XLIII Fully immersive, stereoscopic CAVE-like walk-through environments for visualization, research, oil exploration, military, entertainment, etc.

Task 19: A RoadMap for Education**A roadmap for use of 3D in Education**

Participant: Momentum

Author: C Erdem

Note: This task is additional to those appearing in the DoW.

This roadmap is based upon on-going assessments of the state-of-the-art, and predictions of future developments in education. We analysed the use of 3D in education under five categories, namely methods, features, simulations, applications and standardisation. The most important feature for the success of a 3D educational system is the utilization of a very realistic 3D display, which is expected to exist around the year 2012. Other features such as 3D sound and recreation of the senses such as touch, smell and taste are expected to appear between 2012-2016.

Education		2008	2012	2016	2020
Methods	Authoring tools for scene design and scripting	x	x	x	x
	Use of large collections of 3-D components (objects, avatars etc.) with metadata	x	x	x	x
Features	Support of enhanced interactivity options		x	x	x
	Very realistic displays/tele-immersion (HMD, Autostereoscopic)		x	x	x
	3-D Sound		x	x	x
	Recreation of all five senses (additional senses of touch, smell, and taste)			x	x
Simulations	Video-realistic graphics based on general-purpose stable rendering systems	x	x	x	x
	Integrated persistent worlds	x	x	x	
	Global physics with unlimited world complexity and simulation of most physical aspects		x	x	x
	Realistic simulations of all senses and/or brain-computer interface			x	x
Applications	e-Education/Virtual class/Virtual Laboratories	x	x	x	x
	Professional Training using VR/AR	x	x	x	x
	Surgery simulation/Anatomy lessons	x	x	x	x
	3-D Mobile Education		x	x	x
	Distance Education		x	x	x
	Game-based Education		x	x	x
Standardisation	Standardisation	x	x	x	x

Table T19-1: Roadmap for Education

Simulations of video realistic 3D graphics based educational systems based on general purpose stable rendering systems already exist. However, for realistic simulations of all senses and brain-computer interface, we need to wait about until 2016. Educational systems requiring utilization of global physics with unlimited world complexity and physical aspects are expected to appear around 2012.

Some applications of 3D technology in education already exist such as e-education, surgery simulation and anatomy lessons. However, for other applications such as 3D mobile based education and 3D game based education we may need to wait about 4-5 years. The success of these applications, of course, depend on the success of the aspects discussed in the previous paragraphs.

2.2 Holography and Autostereo (Tasks 4, 5, 6, 7, 9 and 13)

This collection of tasks relates to the underlying technologies, techniques and software required in the development of a 3D display whether it is holography or stereo based. They also link to the RoadMaps discussed in the previous section.

Such areas include an exploration of the requirements of RGB sources like lasers or LEDs for use in either holographic or stereo displays. Some of the requirements are common to any type of display (Task 4). SLM technologies are seen by some as one of the most likely routes to holographic based TV and some of the problems and developments are outlined here (Task 5). Some developments of displays are dependent on improvements in pixel/voxel resolution and packing density, this in turn requires dramatic increases in VLSI technology (Task 6). Of course, it may be that a particular display route is still in its infancy, for example, the developments of PDLC materials for passive holographic displays are outlined here (Task 7). Head tracking techniques are vital to some types of autostereo display and the hardware and software parameters are discussed at length (Task 9). Developments in micro-optics and the associated technologies are also discussed (Task 13).

Task 4: Compact RGB lasers or LEDs**Evaluation of requirements for a small, compact RGB laser or LED source for holographic and/or autostereoscopic displays**

Participants: BIAS, UNIABDN, FhG-HHI, DMU

Author: C. vonKopylow

In this report, the authors discuss some recent advances in the development of RGB light sources. These developments are outlined with regard to their suitability for use in holographic or stereoscopic displays. In the original DoW the perceived requirements for RGB light sources were presented whether this be laser or LED based. Some of the parameters which need to be considered include the output radiant power, optimum wavelengths for good colour rendition, the need for single-frequency operation, the coherence length and the compactness, reliability and robustness of the source. Crucially, requirements regarding laser safety need addressing. In addition, if the display is holographic, then the spatial coherence of the laser should be considered and ought to be as large as the displayed object itself.

Today an RGB source with all the above requirements is not yet available, but significant advances have been made since the start of the 3DTV NoE. In this discussion, much of what we say relates to laser sources and holographic displays but is equally relevant to autostereo displays and LEDs. In the red region of the spectrum laser diodes with a wavelength of more than 650 nm are close to the necessary specifications. Output powers of more than 100 mW are available but still fall short of the target beam parameters. The standard green lasers today are the argon ion and the frequency doubled solid state. The latter are compact but are expensive components, especially for high output power. For single-frequency operation, which is necessary to avoid the noise due to the so called “green problem”, the resonator design is complex. In the blue, as for green, bulky and inefficient argon ion lasers are available as are frequency-doubled solid-state lasers, but the latter suffer from low output power. Reliable high power laser diodes at wavelengths between 405 and 425 nm combined with tapered amplifiers are going to be available in the near future. Currently, such diodes offer powers up to several tens of milliwatts in multimode operation. Recently a new laser type, the diode-pumped semiconductor laser, was developed which can work in the green as well as in the blue. This laser has a similar construction to standard solid-state lasers but can also be designed to emit specific wavelengths. In addition, because of the short length of the active medium (a few microns), single-frequency operation (precondition for low amplitude noise) is achievable with little complexity and low cost. Nevertheless, more development which is stated below is needed to adapt such sources for 3DTV:

- Increased output powers are necessary. Consequently, the thermal management of the laser has to be simulated and a new thermal management strategy must be developed.
- Resonator design must be optimised for frequency-doubling without damaging components and with good heat dissipation.
- Cost effective single frequency operation is needed for low noise operation especially for scanning display systems. To achieve single frequency operation, customised mirror designs or the use of frequency doubling crystals as birefringent filters may be needed. It might even be necessary to introduce additional frequency selecting elements or to incorporate a ring resonator.

- All sources should be enclosed in one housing with integrated beam combiner or with fibre coupling.
- The construction has to be maintenance free: this means a sealed housing with no external adjustments.
- Preferably for good spatial coherence, fibre coupled systems which make the integration in other systems very easy and guarantee an M^2 -value near 1, should be used.

Laser/LED developments

Some interesting recent developments in new sources include an RGB laser utilising quasi-phase-matching and an intermittent oscillating dual-wavelength laser [1]. Generation of red (660 nm), green (532 nm), and blue (440 nm) light is obtained from a diode-side-pumped Q-switched intermittent oscillating dual-wavelength Nd:YAG laser. An average RGB power of 1 W was obtained at an efficiency of 20%. In another development, RGB light was produced using a single-mode tapered fibre pumped by a frequency-doubled Yb fibre laser [2]. The output of the laser was frequency doubled in a periodically-poled lithium niobate (PPLN) crystal to produce green pump light. Spectral brightness of the broadened white light in the tapered fibre was increased by limiting the broadening to the visible wavelengths.

A further paper describes RGB generation in a two-dimensional decagonal quasiperiodic LiNbO_3 nonlinear crystal [3]. Owing to the unique abundance of reciprocal vectors (RVs) in such crystals, the RGB wavelengths are produced directly by frequency doubling, producing much higher conversion efficiencies than previously recorded. Similar results were obtained by rotating the crystal through integral multiples of $\pi/5$. This could help in RGB generation in multiple directions and have important applications in laser projection displays.

Some developments in LED technology include the so-called “nano-wired LEDs” [4]. Such devices can increase the colour range that is obtained from nitride-based semiconductors. These materials form the basis of blue lasers in HD-DVD players but can also emit green and red light. Red, green and blue nano-wired-LEDs can be manufactured from different versions of the same material and can be manufactured on the same substrate. This could result in a brighter, more efficient full colour display with more contrast than current available LC-flatscreens.

A consortium of *Arasor International*, *Novalux* and *Mitsubishi* have developed a variation on the extended cavity surface emitting laser: badged as the “Novalux Extended Cavity Surface Emitting Laser” (“Nescel”) [5]. The fundamental infrared emission of Indium-Gallium-Arsenide semiconductors is converted into visible light by irradiating a lithium niobate crystal. The crystal is so strongly excited it emits many harmonics in the visible.

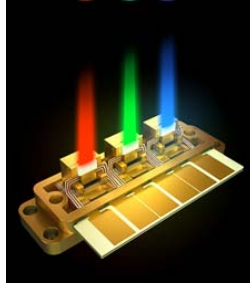

Figure T4-1: Nescel RGB source (see [5])

Soliton Fibrelasers produce a range of colours in powers of up to 2W at 560nm, 1 W at 580 nm and 200 mW at 592 nm [6]. A blue laser is conspicuous by its absence.

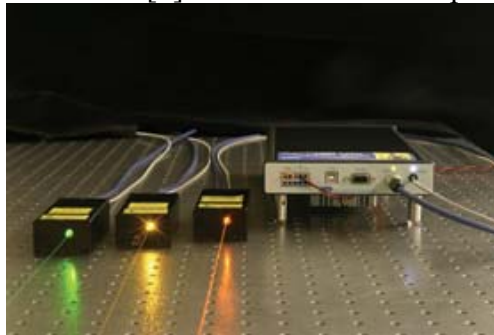

Figure T4-2: lasers from the *Soliton Fibrelasers* range (see [6]).

Projection Laser TV systems

Mitsubishi recently unveiled their first laser television based on a backprojection screen with a 16:9 format and a 50-inch diagonal [7]. The laser light sources illuminate a digital light projector LP unit (a DMD) consisting of thousands of vibrating micro mirrors. This enables generation of a doubled colour spectrum in comparison to the current technology. The infrared light of the new VCSEL laser diodes is converted into the visible region with the help of lithium niobate crystals resulting in red, green and blue laser light (see above). The laser TV uses less electricity than LCD plasma screens.

Some other interesting developments include a laser projection system based diode-pumped solid state lasers from *Jenoptik LDT* [8]. Although claiming HD-resolution, it is not full colour (13 bit) and the separate laser is large. It was developed for flight simulators and planetariums.

Green lasers with high efficiency are keystone components for mobile projectors. Up until now, final miniaturisation meets a roadblock at the green laser stage – in contrast to red and blue, green is not readily obtainable in a compact design. In a series of developments, *Corning* and *Osram* have demonstrated a miniature laser (<0.7 cm³ volume) that utilizes adaptive optics for operation over a 50 °C temperature range without requiring a thermo-electric cooler [9]. The use of adaptive optics also helps in reducing the cost of the laser assembly.

A key aspect of using a laser in any display system is the presence of laser speckle. This effect degrades image quality and perception. In a novel approach *Light Blue*

Optics (LBO) offer a miniature “holographic” projector [10]. However, the term “holographic” refers not to the image, but to the method of projection. A diffraction pattern of the desired 2D image, calculated using LBO’s patented holographic algorithms, is displayed on a custom-designed phase-modulating Liquid Crystal on Silicon (LCOS) microdisplay. When illuminated by coherent laser light, the desired 2D image is projected.

Conclusion

In the last few years, new developments in laser technology have led to systems that are very promising for 3DTV and its application. Of particular importance has been the development of very compact, all solid state solutions such as frequency-doubled solid state lasers, fibre lasers and laser diodes. These have all opened new paths for the illumination of different types of displays. It is expected that these new solutions will reach readiness for marketing very soon. Of those the most promising from our point-of-view are frequency-converted VCSEL laser diodes and by frequency-doubled fibre lasers. Both can be manufactured easily at high quantities and are very reliable light sources.

References

1. X. P. Hu, G. Zhao, Z. Yan, X. Wang, Z. D. Gao, H. Liu, J. L. He, and S. N. Zhu, **High-power red-green-blue laser light source based on intermittent oscillating dual-wavelength Nd:YAG laser with a cascaded LiTaO₃ superlattice**, *Optics Letters*, Vol. 33, Issue 4, pp. 408-410, (2008); <http://www.opticsinfobase.org/abstract.cfm?URI=ol-33-4-408>
2. M. Rusu, Samuli Kivistö, C. Gawith, and O. Okhotnikov, **Red-green-blue (RGB) light generator using tapered fiber pumped with a frequency-doubled Yb-fiber laser**, *Optics Express*, Vol. 13, Issue 21, pp. 8547-8554, (2005); <http://www.opticsinfobase.org/abstract.cfm?URI=oe-13-21-8547>
3. **Effective generation of red-green-blue laser in a two-dimensional decagonal photonic superlattice**, *Applied Physics B: Lasers and Optics*, Volume 87, Number 4 / June 2007, p.603-606, (China 2007); <http://www.springerlink.com/content/j071080lu5nt260k>;
4. <http://www.heise.de/tr/LEDs-aus-Nanodraehten--/artikel/94565/> (21.08.07);
5. <http://www.heise.de/tr/Laser-TV-zweiter-Anlauf--/artikel/87382/1/0>, (27.03.07);
6. Source: http://www.soliton-gmbh.de/LaseruMess2-2_e.html#Produkt71; RGB LED/SLEDs not on the homepage.
7. <http://satundkabel.magnus.de/satellit/artikel/ces-2008-mitsubishi-zeigt-lasertv-volle-hdtv-aufloesung-und-dlp-technik.html>, (8.01.08);
8. <http://www.jenoptik-laserdisplay.de/cps/rde/xchg/SID-26EE34DB-0FB9A402/ldt/hs.xsl/3889.htm>, (30.05.08)
9. Vikram Bhatia, Steven J. Gregorski, Dragan Pikula, Satish C. Chaparala, David A. S. Loeber, and Jacques Gollier, Yukihiro Ozeki, Yoshiaki Hata, Kazuhiro Shibatani, Fumio Nagai, Yukinobu Nakabayashi, Naoki Mitsugi, and Satoshi Nakano; **Corning (Whitepaper): Efficient and Compact Green Laser Incorporating Adaptive Optics for Wide Operating Temperature Range**, <http://www.corning.com/WorkArea/linkit.aspx?LinkIdentifier=id&ItemID=10535>; http://www.corning.com/r_d/emerging_technologies/green_laser/technical_library.aspx, (2007-2008); <http://www.heise.de/newsticker/Picobeamer-stets-fokussiert-dank-Laserlicht-/meldung/108399/from/rss09> (24.05.08)
10. Source: <http://www.lightblueoptics.com/technology.htm> (2008)

Task 5: Future SLM Developments

Evaluation and technical assessment of current and future SLM technologies and their suitability for 3DTV and related applications

Participants: UNIABDN, Bilkent, BIAS, CLOSPI-BAS

Author: F. Yaras

Introduction

Spatial Light Modulators (SLMs) are devices that can impose spatially and temporally varying modulation on an optical wavefront by varying amplitude, phase and polarisation. For holography, photographic films are commonly used and preferred due to their high resolution and high space-bandwidth product. However, they are not suitable for digital holography or real-time applications such as holographic displays. As computer generated holograms (CGHs) grow in importance, SLMs are favoured for real-time applications because of their ease-of-use and availability. Contrary to photographic films, with the help of the CGHs and SLM technology, holograms now can be calculated and reconstructed rapidly. However, there are some adverse effects such as low resolution, fewer higher diffraction orders, limited viewing angle and low diffraction efficiency. It is apparent that by choosing SLMs as a holographic display infrastructure, we have to work with these drawbacks to some extent.

Compared to conventional holograms, the primary disadvantage of SLMs is the low space-bandwidth product (SW). For a 2D signal, SW is defined as [1]:

$$SW = \Delta x \Delta \nu_x \Delta y \Delta \nu_y \quad (1)$$

where Δx and Δy represent spatial resolution and $\Delta \nu_x$ and $\Delta \nu_y$ represent frequency resolution. For a typical conventional hologram, with a resolution of 3000 lines/mm and a size of 20 cm² SW is in the order of 10¹⁰, whereas for current SLMs SW is about 10⁷. This is a severe drawback for holographic displays since low SW decreases resolution. In addition to space-bandwidth product, viewing angle is one of the most important features in digital holography. Due to large pixel sizes, viewing angle is severely limited 1-2° depending on the wavelength as seen in Eq.2.

$$\Theta = \arcsin(\lambda/(2\Delta\xi)) \quad (2)$$

where Θ is the maximum viewing angle, λ is the wavelength of the backlight and $\Delta\xi$ is the pixel pitch.

SLMs can be classified by their modulation mechanism (e.g. mechanical, magnetic, electrical, and thermal), modulation variable (phase, intensity, and polarisation) and addressing mode (electrically and optically). However, in the literature the main classification is by their addressing mode: electrically addressed spatial light modulators (EASLMs) and optically addressed spatial light modulators (OASLMs).

*SLM Technologies*Electrically Addressed Spatial Light Modulators

EASLMs convert electrical signals to a spatial modulation. Each pixel can be controlled by computer through VGA or DVI outputs. They are easy to use and with the help of the suitable drivers, are compatible with many computer systems. EASLMs are used not only in digital holography but also in image projection, optical beam steering, optical neural systems, optical switching and so on. However, since all EASLMs have a pixellated structure, higher diffraction orders become a problem for coherent optical processing. Therefore, incoherent optical processes may be more advantageous for this type of SLMs. There are many commercial EASLMs in the market, however most populars are Liquid Crystal (LC), Liquid Crystal on Silicon (LCoS) and Digital Mirror Devices (DMD).

LIQUID CRYSTAL SPATIAL LIGHT MODULATORS

Due to the anisotropic nature of liquid crystals, optical properties may change with illumination and are therefore suitable for using as a display material. By addressing a pixel, an electric field is applied to the liquid crystal layer to switch that pixel on or off. In order to achieve greyscale pixels, time alternating methods are used. For generating colour images, either three SLMs are used for red, blue and green components or three pixels are grouped as one and are covered individually with red, blue, and green colour filters. As a holographic display, single SLMs operating in greyscale are preferred for coherent optical processes such as digital holography. With LC SLMs, amplitude and/or phase modulation are possible. However, due to low diffraction efficiency and fewer higher diffraction orders, phase modulation is often chosen.

Transmissive LC SLMs are amongst the most common types. Depending on the orientation and refractive index of the crystal, the polarisation or the phase of the light is modulated. For intensity modulation, this is accomplished by two polarisers over the surfaces of the liquid crystal layer and varying the polarisation of the crystal.

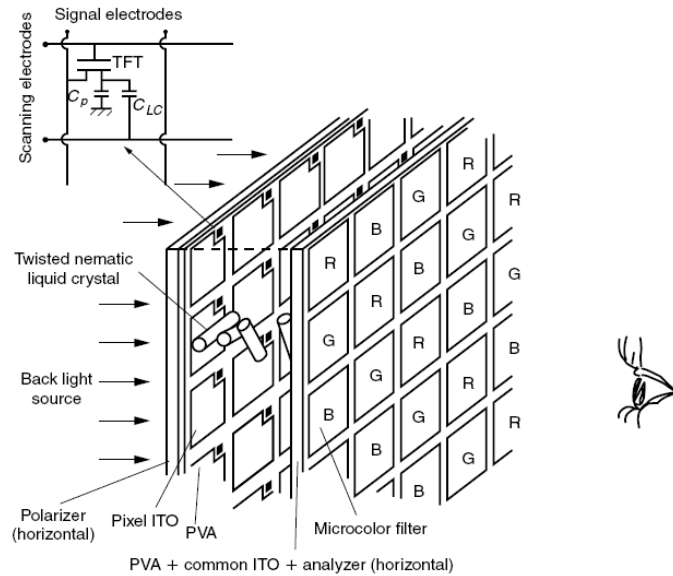

Figure T5-1: Liquid Crystal Display using a LC SLM [after 4]

One crucial property of LC SLMs is its “fill-factor”. The fill-factor of LC SLMs are rather low due to physical limitations. The transistor pixel dimensions cannot be decreased indefinitely. Therefore, while the pixel area is reducing, transistor sizes remain unchanged. This affects the fill-factor and severely reduces the transmitted optical power. Transmissive LC SLMs are commonly used for monitors, LCD televisions and are also used for digital holography. They can even support high-definition (HD) resolutions with pixel sizes of $12\ \mu\text{m}$. The fill-factor of transmissive LC SLMs is between 40% and 80%. For digital holography, pixel sizes of LC SLMs are still too large. Therefore, viewing angle is limited to 1 or 2° depending on the wavelength as seen in Eqn. 2.

Ferroelectric transmissive LC SLMs are also commonly used in digital holography due to their fast refresh rate. Although they operate in binary mode, they can provide refresh rates up to $2 - 3\ \text{kHz}$. Therefore, those LC SLMs are preferred for tiling of the holographic patterns onto a photosensitive materials and devices at video rates as seen later in Figure T5-6.

Another popular LC SLM type is the Holographic Polymer Dispersed Liquid Crystal (HPDLC). They are manufactured by dispersing LC nano-scale droplets in a photopolymer film. In the absence of an electric field, nematic liquid crystal molecules align arbitrarily and therefore liquid crystal layer behaves as a scattered medium. When voltage applied to the SLM, due to positive birefringence crystals align on-axis and light travel through the layer with minimum attenuation [4]. Figure T5-2 shows the PDLC states and its application to fibre optic cables. HPDLC SLMs have favourable properties such as full colour support, high contrast, high resolution, low cost and low power consumption and also disadvantages like high voltage operation and limited viewing angle.

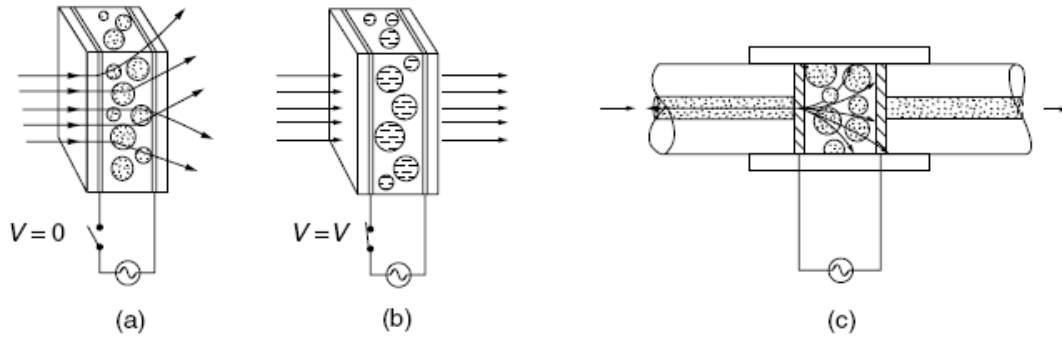

Figure T2-2: Polymer-dispersed liquid crystal (PDLC) light modulator, (a) Off state. (b) On state. (c) Fibre optic light modulator[after 4]

LIQUID CRYSTAL ON SILICON SPATIAL LIGHT MODULATORS (LCoS SLMs)

LCoS SLMs operate in a similar way to LC SLMs, however they work in reflection mode and mirrors at the back-plane of the SLM are used as an electrode to apply an electric field to the liquid crystal layer. Light passes through the liquid crystal twice, therefore LCoS SLMs can provide better phase shift than transmissive LC SLMs. Another advantage is the high fill-factor which is above 90%. Due to mirror electrodes, there is no need for transistors. Most common LCoS SLMs operate in phase-only mode. Due to favourable properties of phase holograms such as high diffraction efficiency, low diffraction orders and ease of removing undiffracted beam in on-axis phase holograms, LCoS phase-only SLMs are popular in digital holography. In addition, they are one of the most promising SLM technologies in holographic displays due to the low pixel sizes. LCoS SLMs with 8 μm pixel pitch are readily available. Due to small pixel sizes, the viewing angle is potentially larger. A photo of an LCoS SLM is shown in Figure T5-3.



Figure T5-3 Holoeye HEO1080P LCoS SLM [after 2]

DIGITAL MIRROR DEVICES (DMDs)

Another type of EASLM is the digital mirror device. DMDs modulate light by an array of electromechanically moveable micro-mirrors. DMDs have several advantages over LC SLMs such as optical power efficiency. Since DMDs are mirror based modulators, light does not pass through the medium therefore there is little optical power loss compared to LC SLMs. Another advantage is a higher refresh rate.

The Digital Micro-mirror Device (same acronym, DMD) is a trademark of the *Texas Instruments* and is the most popular DMD on the market for projection systems [3]. An array of tiltable micro-mirrors is controlled via electrostatic charge distribution by addressable binary data. Pixels can be either turned on or off by tilting the corresponding micro-mirrors. DMDs have great advantages over LC SLMs for real image holography due to its reflective technology. However, the pixel pitch of the DMDs which are about $10\ \mu\text{m}$, have to be improved to have larger viewing angle.

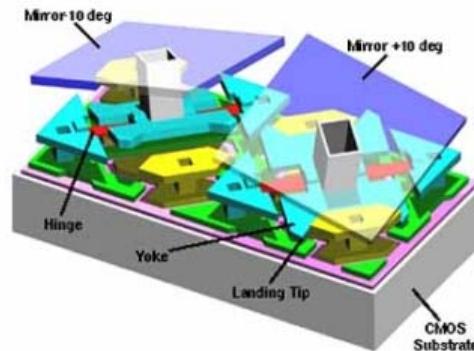

Figure T5-4 Schematic of a pair of DMDs [after 3]

Optically Addressed Spatial Light Modulators

Although OASLMs have favourable properties, they are not as popular as EASLMs due to operational complications. They convert intensity patterns into a phase or amplitude modulation. The writing side of the OASLM is illuminated by an intensity pattern and a 2D modulation of the refractive index in the liquid crystal layer is generated at the reading side. When the read-out light is exposed to the reading side, light is modulated and reflected as an output. Unlike other SLMs they are not pixelated and therefore high diffraction orders do not exist. The resolution of OASLMs is around 200 lines/mm and it is very low compared to photographic holograms. Applications of OASLMs include wavelength conversion and incoherent-coherent conversion. Disadvantages of OASLMs include write-in speed: the response time of materials used in OASLMs is slow and have an adverse effect in real-time digital holography. In order to overcome this, OASLMs are coupled with EASLMs in active tiling methods [5]. In this method, large diffraction patterns are divided into tiles and each tile is exposed by the EASLM onto the OASLM (Figure T5-6). After tiling is finished, the read-out light is exposed and modulated by the diffraction pattern written on the OASLM.

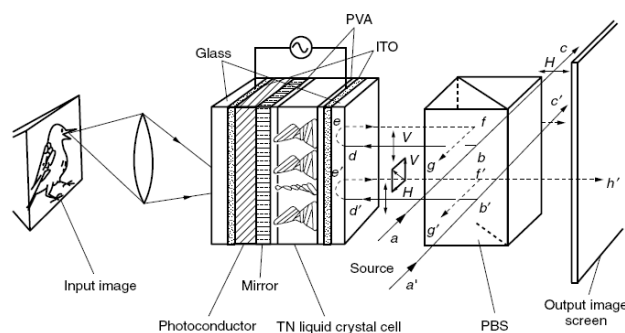

Figure T5-5 Optically addressed spatial light modulator [after 4]

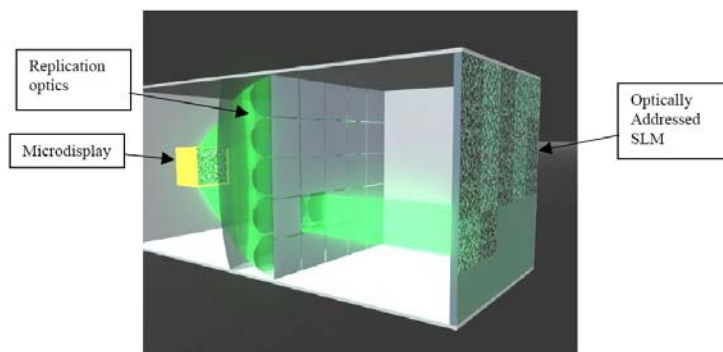

Figure T5-5: Illustration of the Active Tiling modulator [after 5]

Work carried out within the Network

The above represents a broad overview of the current state of SLM technology. Work has been undertaken at several Institutions within the 3DTV NoE. Laboratories for the study of SLM techniques and their application have been set up at both Aberdeen and Bilkent Universities. Research into PDLCs is being undertaken at CLOSPI-BAS and BIAS have a long-standing research track in SLMs.

At Aberdeen a Holoeye Reflective SLM (Brilliant 1080 – 1820x1220 – 8.1 μm pixels) was purchased. Several papers have been published on the properties and use of this SLM (see Papers 2 and 34 in this report and [6]). It is worth noting that this work was conducted in parallel with NoE researchers at MPG. At Bilkent work concentrated on the use of DMD's and also on the HoloEye Transmissive SLM. Again several papers resulted from this work (see Papers 4 and 5). At CLOSPI work concentrated on polymer dispersed liquid crystals (See Papers 7 and 8).

References

1. D. Mendlovic, Z. Zalevsky, A.W. Lohmann, R.G. Dorsch and C. Ferreira. "Space-bandwidth product of optical signals and systems". *J. Opt. Soc. Am. A*, vol.13, pp. 470--473, 1996.
2. HOLOEYE Photonics AG. "HDTV Phase Panel Developer Kit", *HEO 1080P Application Note*, Dec, 2006.
3. P. F. V. Kessel, L. J. Hornbeck, R.E. Meier and M. R. Douglass. "A MEMS-Based projection display", *P. IEEE*, vol.86, pp. 1687--1704, 1998.
4. K. Iizuka. "Elements of Photonics", *Wiley-IEEE*, 2002.
5. S. D. Coomber, C. D. Cameron, J. R. Hughes, D. T. Sheerin, C. W. Slinger, M. A. Smith, M. Stanley. "Optically addressed spatial light modulators for replaying computer-generated holograms", *Proc. SPIE*, vol.4457, pp. 9--19, 2001.
6. L. Ahrenberg, P. Benzie, M. Magnor, J. Watson, "Computer Holography using Parallel Commodity Graphics Hardware", *App Optics*, 14, 7636-7641 (2006)

Task 6: VLSI Technology**Investigation and technical assessment of VLSI Technology and targets for the future**

Participants: UNIABDN, Bilkent, BIAS

Author: D. Hendry

The purpose of this task was to survey and report on the availability of VLSI support for 3DTV designs including both semiconductor process support and design tool support for those aspects of 3DTV such as signal processing and display systems that are likely to require substantial digital processing support. During the lifetime of the NoE VLSI technology and support tools have been surveyed on two occasions to provide a picture of the current state of VLSI and trends in VLSI technology relevant to 3DTV. The most telling points that have been noted are:

- the continuing reduction in feature size that has both occurred and is continuing to be predicted by the semiconductor industry;
- the continuing emergence of FPGAs (Field Programmable Gate Arrays) as a rapid and highly capable means of implementing algorithms for research purposes and for use in products; and
- the availability of increasingly domain specific design tools for signal processing that will be of value to 3DTV researchers.

Introduction:

VLSI will be a major implementation technology for 3D-TV systems. Given the complexity of the algorithms involved, substantial signal processing power is required for scene acquisition, data compression, transmission and decoding. Commercialisation of project results is expected to be heavily reliant on VLSI devices. In the shorter term, during the lifetime of the project, VLSI technology provides a means of prototyping algorithms with sufficient performance to evaluate their effectiveness. The NoE has surveyed the state of the art in VLSI (as represented by that industry's roadmaps) and VLSI design tools on two occasions to inform the NoE participants with a requirement for VLSI support. This report summarizes the trends and results of those two reviews.

Process Technologies.

Reduction in feature size is a well-publicized feature of VLSI technology, with current commercial processes now manufacturing devices with gate lengths as low as 50 nm. In the first survey of the VLSI technology the roadmap for semiconductor device development, the International Technology Roadmap for Semiconductors [1], predicted in the 2004 roadmap that minimum feature size (MPU gate length) in the most aggressive processes would reach 25 nm by 2010. This was updated however by the time of the next review of VLSI to 18 nm. The same update predicts a maximum transistor count per chip of 62 giga transistors by 2020, the earliest point in time at which we might expect to see large scale commercial exploitation of 3DTV technologies. As at the first review, the second review again concluded that power dissipation was a more likely limitation on VLSI devices applied to 3DTV technologies.

Recent developments in the understanding of process limitations are small feature sizes indicate that statistical variation in device performance may pose a substantial barrier to further reduction in feature size [2].

Programmable Devices.

While the capability of VLSI devices, including ASICs, is increasing at a steady pace, the cost of developing such devices is also increasing to the point that the number of new designs starting per annum is now decreasing. Programmable devices however provide an increasingly competent approach to the rapid implementation of all but the most complex devices. While such devices cannot compete with an ASIC solution in terms of manufacturing cost per part (in very large numbers), power dissipation or clock speed, the vastly reduced development costs and reduced design risk make the use of FPGAs very attractive for certainly research applications, and for commercial production for all but the largest quantities.

Programmable devices, principally FPGAs remain in both reviews of VLSI technology, the primary mechanism by which future research in 3D-TV algorithms may be implemented in hardware. The first review carried out by the NoE identified a number of promising devices for hardware implementation of 3D-TV algorithms in future work.

Design Systems.

During the course of the two reviews carried out by the NoE design tools for VLSI devices have of course developed in a number of directions. For ASIC design, and the majority of programmable logic design, remains based on RTL (Register Transfer Level) design techniques using languages such as VHDL and Verilog.

Physical design of systems is becoming increasingly complex due to both the increasing physical complexity of VLSI systems, and the desire to obtain ever tighter bounds on system performance calculations at design time. CAD tool vendors have, over the period of the NoE, introduced or expanded the capability of a number of new tools. These include longstanding tools such as place and route, but also tools for improved power estimation, power distribution and statistical design or circuits.

It was noted in the first review, and increasingly in the second review, that design tools were available for domain specific areas, the prime example being DSP that has been supported in VLSI design since the 1980s. Increasing integration of such domain specific tools with logic synthesis permits the mapping of algorithms onto both VLSI devices (with use of backend place and route tools) or to FPGAs in a largely automatic manner. The latter approach using FPGAs led to the introduction in the second review of a section on Re-configurable computing systems.

Reconfigurable Computing Systems.

The situation noted in the second review was “Again for research purposes, re-configurable computing systems provide a flexible platform for algorithm exploration. Such systems may be seen as either a platform for the exploration of hardware implementations of algorithms, or as an accelerator for compute intensive applications. Design entry in such systems is optionally at a high level (for example Handel-C, a C like language), or at register transfer level (VHDL, Verilog).” This situation remains and will possibly provide the most effect route for further 3D-TV

research. Experience of such systems within the NoE does indicate that there are limitations imposed not by problems inherent in the technology, but due to the limitations of current re-configurable products.

Conclusions.

The two review carried out by the NoE have provided guidelines for the use of VLSI technologies within the NoE and for future 3D-TV related work. This is essentially a communication exercise within those in the NoE with an interest in VLSI hardware, particularly for the computationally intense work needed in displays.

References

1. International Technology Roadmap for Semiconductors, <http://www.itrs.net>
2. See for example Asenov et al “Simulation of Intrinsic Parameter Fluctuations in Decanometer and Nanometer-Scale MOSFETS” IEEE Trans Electron Devices 50, 1837 – 1851 (Sept 2003)

Task 7: New SLM Materials**Evaluation and technical assessment of new materials (e.g. PDLC's) for SLM's**

Participants: CLOSPI-BAS, UNIABDN

Author: S. Sainov

Photorefractive organic materials [1]

1994 was a turning point in the development of photorefractive polymers. The chromophores design was changed – the Pockels effect was replaced by orientational birefringence as the main driving mechanism. On this basis, the refractive index of the material is modulated by the orientation of the optically anisotropic dopant molecules with permanent dipole moment control. This is a consequence of the internal space charge field generation, driven by absorption, charge generation, separation and trapping, similar to traditional photorefractive materials.

In fact, all known photorefractive materials up until 1990 were inorganic crystals. Photorefractivity in an organic crystal was first reported by the ETH Zurich group in 1990. The material was a carefully grown nonlinear organic crystal *2-cyclooctylamino-5-nitropyridine* doped with *7,7,8,8-tetracyanoquinodimethane*. Although the growth of high-quality doped organic crystal is a difficult process, since most of the dopants are expelled during the crystal preparation, there were some subsequent investigations of such media. On the other hand, polymeric and/or glassy materials can be doped relatively easy with various molecules with different sizes. In addition, polymers may be formed into different shaped thin films as well as total internal reflection and waveguide configurations according to the application requirements. The first polymeric photorefractive material was composed of an optically nonlinear epoxy polymer *bisphenol-A-diglycidylether 4-nitro-1,2-phenylenediamine*, which was made photoconductive by doping with 30 wt% of the hole transport agent *diethylaminobenzaldehydediphenylhydrazone*. Shortly after, it was used for holographic recording. Another approach which does not involve doping electro-optical polymers with charge transport molecules, employs synthesis of a fully functionalized side-chain polymer with multifunctional groups. Nevertheless, a faster and easier to implement method is the “quest-host” chemical design. It enables a way to test different combinations of polymers and molecules with photosensitivity, transport and optical activity.

Liquid crystals

In 1994, the first photorefractive liquid crystal materials were reported. The low-molarmass liquid crystalline material *40-pentyl-4-biphenylcarbonitrile*, doped with small amounts of a sensitizing laser dye *rhodamine 6G* was used. In fact, the ultimate extension of orientational photorefractivity is to consider materials consisting entirely of long, rod-shaped birefringent molecules, which can be easily oriented in external electric field, i.e. the liquid crystals. It is well known, that nematic liquid crystals possess large optical nonlinearities associated with director-axis orientation in consequence of optical or electric field application. In many aspects, they are ideal for observing the photorefractive effect, due to the specific design in order to obtain orientational response. In addition, no nonlinear dopant is necessary, since the liquid crystal is itself the birefringent component. It is essential that in liquid crystals 100% of the medium contribute to the birefringence in contrast to the nonlinear optical dopant in other systems. Furthermore, the molecules response to the space charge

field is lower with an order of magnitude compared to polymers. As a comparison, the required field for photorefractive liquid crystal reorientation is approximately $0.1 \text{ V}/\mu\text{m}$, while in polymer systems it is about $50 \text{ V}/\mu\text{m}$. Along with these advantages, the figure of merit, compared to polymers, rapidly improved in consequence of new liquid crystal mixtures formulations and a better understanding of the charge transfer processes.

Polymers

In fact, enhanced optical reorientation through dye doping is not limited only to liquid crystals, but is also present in isotropic liquids and amorphous polymers. Although polymers are most often described as a promising medium for high-density optical storage, they also find applications in real-time holography. Among the most studied dynamic polymeric holographic media, are the *azo*-containing materials.

In any case, both *azobenzene* LC and amorphous polymers exhibiting photo-isomerisation and surface relief creation show excellent holographic characteristics. The photo-isomerisation mechanism allows wider spectral sensitivity, up to 633 nm, while the surface relief materials usually work in the range of 244 - 532 nm. The spatial frequency gained is 6000 and 3000 lines/mm, respectively. The refractive index modulation exceeds 0.1.

Nevertheless, the pursuit for dynamic holographic materials development has expanded the range of available media, mostly by composites development in order to combine the advantages of different materials like liquid crystals or various polymers. In fact, improvements in the holographic characteristics of these materials are linked to composite materials development. On the one hand, the possibility of combining the very large reorientational effects exhibited by low molar-mass LCs with the longer grating lifetimes and higher resolution of non-*mesogenic* polymers is extremely attractive. Furthermore, the combination of liquid crystals and photopolymers enables the realisation of switchable gratings, which find many practical applications. These materials are recognised as polymer dispersed liquid crystals (PDLC) and will be discussed in details in the following section.

Polymer dispersed liquid crystals [2-5]

Polymer dispersed liquid crystals (PDLC) are relatively new materials, elaborated over the last two decades. Although they were first considered for other applications, they were later applied to holographic recording. The first applications of PDLCs were the so-called “smart windows” formed by homogeneously distributed liquid crystal droplets in polymer matrix. Their optical behaviour is electrically controlled. Later, switchable holographic gratings recording opened up many applications as holographic optical elements (HOEs). Another direction in PDLC development is to use the photorefractive effect in order to obtain reversible recording.

The phase separation in PDLCs, can be accomplished by several mechanisms. Thermal methods utilise a thermoplastic material with liquid crystal cooling. Another method is solvent-induced phase separation. Nevertheless, the most established technique nowadays is to employ polymerisation of monomeric precursors homogenised with the liquid crystal, *viz.*, polymerisation-induced phase separation. This latter case can be achieved optically by UV irradiation. The next stage consists of free radical reactions initiating monomer-polymer conversion, which leads to an

increase of the polymer molecular weight in the presence of large volume fractions of liquid crystal. The final morphology consists of randomly dispersed liquid crystal domains with form, volume proportion and size determined by the illuminating light intensity, the volume ratio of the compounds in the pre-polymer mixture and the temperature. It is essential to note that the morphology determines the further electro-optical properties of the film.

Depending on the liquid crystal concentration, two main types of morphologies are observed after the phase separation process. In the case of relatively low amounts of liquid crystal, the morphology is “Swiss cheese” type: spherical or ellipsoidal droplets are completely embraced by the polymer matrix. The other type of morphology consists of two continuous phases (polymeric and liquid crystalline), described as the “sponge” morphology. This is usually observed at liquid crystal concentrations exceeding 50%. A typical feature of this morphology is the coalescence of the liquid droplets. At a given liquid crystal concentration, the droplet size and distribution is determined by the polymerization kinetics. If the liquid crystal is extracted from the structure, the morphology can be observed by electron microscopy techniques.

After the initial droplets formation, its size increases because of liquid crystal diffusion from the areas where the polymer concentration (due to the polymerization process) increases rapidly. The droplet size and their distribution is determined not only by the diffusion process, but also by the polymer network propagation leading to “gelation” over a given molecular weight and density of the matrix. At this moment, the diffusion significantly diminishes and the droplet size (and shape) is fixed. Diameters from 0.02 to several micrometres are obtained. The control of the diameter is required for optimisation of the further electro-optical properties of the material.

The droplets distribution is random, except for the cases when special surface treatment is performed in order to create preliminary orientation of a layer of the material. Within the droplets some kind of arrangement presents, it is usually nematic, but the overall direction of the molecular axes (the director) is different in each droplet. At all, the director configuration within the droplet is dependent on the surface interaction, the elastic constants of the liquid crystal and the presence of external applied field and its amplitude. In most of the cases, the optical axis (determined by the dipole momentum) coincides with the molecular. In consequence of the chaotic director distribution, the material is “opaque” and strongly diffuses the light.

On the base of controlled light scattering, PDLCs find application in optoelectronics for different transmission windows, temperature sensors, colour filters with variable optical density, etc.

The holographically formed PDLC structure consists of polymer reach and liquid crystal reach layers, following the light distribution. Again, due to the refractive indices mismatch, scattering occurs. Due to the periodicity of the structure this scattering is coherent and lead to reconstruction of the holographic information. Thus, the medium exhibit phase modulation and the structures are known as holographic polymer dispersed liquid crystals (HPDLC).

Similar to conventional PDLCs, the ordinary refractive index of the liquid crystal is chosen to match the one of the polymer matrices. As a result, the application of electric field leads to switching off, of the diffraction structure, since the index modulation disappears. Again, when the electric field is removed, the liquid crystal restores its initial configuration governed by the elastic forces. The consequence of this mechanism is the reversible switching of the diffraction grating.

The sensitizing of HPDLC in the visible spectral range, actually to some proper laser wavelengths is fulfilled by addition of appropriate combination of dye and photoinitiator. The role of the dye assists in translation of the material absorption peak in the desired spectral range, while the photoinitiator is important for the free-radical polymerization processes initiation. It is believed that process exhibits the following mechanism. The photon absorption is accompanied by excitation of the dye molecule. The next process is electron transfer from the excited dye molecule to the initiator, usually belonging to the group of the amines. In consequence, a pair of ion radicals is formed. This process is immediately followed by proton transfer to the anion radical of the initiator from the co-initiator. As a result, a neutral amine radical is obtained which initiates the photopolymerization. This efficiency results in higher polymerization velocity, which influences the size and the anisotropy of the droplets.

In order to obtain high diffraction efficiency along with high spatial resolution, in the case of reflection diffraction gratings, morphology with high concentration of small liquid crystal droplets is required.

As a consequence of the HPDLC new materials elaboration and optimization, the following holographic characteristics are obtained:

- Spectral sensitivity in almost the whole visible range as well as in the infrared, 770-870nm, through the utilization of different dyes;
- Spatial frequency $> 6000 \text{ mm}^{-1}$;
- Refractive index modulation $\Delta n \sim 0.05$.

HPDLC's find many applications as HOE's in areas like photonic crystals, high-density information recording, electrically controlled diffractive elements: tuneable focus lenses, electro-optical filters, interconnectors and other elements for fibre optics. They have recently been used as elements in information security systems and feedback elements of compact laser in order to flip the generated wavelength. Polarisation holographic gratings in PDLC have also been reported.

First considered for display applications, HPDLC's remain one of the most attractive candidates for the different approaches for colour and 3D displays. HPDLC enable colour separation is also applicable to image capturing. Another approach is to use waveguide holograms. Investigations of HPDLC's at total internal reflection geometries are already performed. Slanted transmission diffraction gratings, where the applied electric field controls the total internal reflection conditions for the horizontally polarized light vector (electric vector parallel to the incident plane) are realized. Stetson and Nassenstein holographic gratings, allowing total internal reflection and evanescent wave recording in extremely thin layers, have also been successfully recorded.

Conclusion

The realisation of a 3D holographic display is a challenging task. It requires 3-dimensional scene encoding, in terms of optical diffraction, transformation into fringe patterns of the hologram, signal conversion for a spatial light modulator and display in real time. The ultimate element of this device should be a fast dynamic holographic material possessing high spatial resolution capability. Another problem is the limitations of available spatial light modulators, which scarcely satisfy the demands of holographic display systems. Since the critical point is their poor spatial resolution, a possible solution is to synthesise the whole diffraction structure in parts, i.e. to transfer the diffraction structure from the spatial light modulator to the reversible recording media by multiplication.

Thus, the final device should comprise a certain number of elements, including switchable diffractive optics and reversible recording media. The best candidate for the switchable optical elements seems to be the nano-sized composite polymer-dispersed liquid crystals. They possess the main advantages of the organic media, i.e. simple (dry), one step processing, high sensitivity, proper mechanical characteristics (plasticity) allowing easy integration in different compact devices, as well as high signal to noise ratio and spatial resolution. Recently, most of the efforts is directed towards improving the electro-optical performance, to employ total internal holographic recording set-ups as well as to develop new PDLC mixtures.

Other promising candidates are the dye-doped liquid crystals and photochromic materials. An advantage of these recording media is the absence of electric field in the write or read process. The required properties of this class of materials can be summarised as follows: thermal stability of both isomers; resistance to fatigue during cyclic write and erase processes; fast response; high sensitivity.

Most probably, in the near future the investigations in the field of materials for display and switchable diffractive devices should concentrate on nano-particle-liquid crystal composites. The current development of nano-particles dispersions has shown excellent holographic characteristics. The main advantage is the possibility to obtain extremely high refractive index modulation, since materials like TiO₂ have a refractive index approaching 3. In addition, low shrinkage and good sensitivity are obtained. In general, the process is similar to HPDLC grating formation: the photopolymerization process initiates mass transfer of the components. The challenge is to combine low-energy consuming liquid crystal devices with the possibility to enhance the modulation by nano-particles redistributions and to obtain reversible diffractive structures formation.

References

1. K. Beev, K. Beeva, S. Sainov, "Materials for holographic display applications" Chapter of the book "Three-Dimensional Television: Capture, Transmission, and Display", Editors: Haldun M. Ozaktas and Levent Onural, Springer Berlin Heidelberg, 2007, DOI: 10.1007/978-3-540-72532-9; ISBN: 978-3-540-72531-2 (Print) 978-3-540-72532-9 (Online), pp. 557-598.
2. K. Beev, S. Sainov, T. Angelov, A. G. Petrov, "Holographic Recording in Polymer-Dispersed Liquid Crystals", Proc. SPIE, 5830, pp. 90-94 (2004)
3. K. Beev, S. Sainov, T. Angelov, A. G. Petrov, "Investigation of bragg gratings recorded in polymer-dispersed liquid crystals", J. of Optoelectronics and Advanced Materials, v.6 (3), pp. 799- 803, 2004

4. S.Sainov, K. Beev, F. Simoni. J. Watson, "New investigations of polymer dispersed liquid crystals for display applications", 2nd Workshop on Immersive Communication and Broadcast Systems (ICOB 2005), 2005
5. S.Sainov, K. Beev, F. Simoni. J. Watson, "New investigations of polymer dispersed liquid crystals for display applications", 2nd Workshop on Immersive Communication and Broadcast Systems (ICOB 2005), 2005
6. S. Sainov, V. Sainov, J. Dikova, K. Beev, "Optical and holographic properties of nano-sized amorphous semiconductor films as a part of optically addressed spatial light modulator", IEEE DOI: 10.1109/3DTV.2007.4379466, 2007

Task 9: Hardware & Software for Head-tracking

Evaluation and specification of hardware and software requirements for multi-user head tracking systems

Participants: FhG-HHI, DMU, FogS

Authors: K. Hopf, P. Surman, I. Sexton, I. Rakkolainen

Description

Next generation multi-user 3D displays will be based on head tracking technologies. Due to the fact that a robust real-time non-intrusive head tracking technology for multiple viewers does not yet exist, this task will evaluate the requirements of a suitable tracking technology. Based on existing single-user technology [1], technical and Human Factors needs of multi-user 3D displays the hardware and software parameters of a suitable head tracking system will be specified and recommended.

Summary of Joint Work

State-of-the-Art has been evaluated:

- Electromagnetic tracking
- Acoustic tracking
- Inertial tracking
- Optical tracking

From the human factors position it is unacceptable for most 3D display applications to use intrusive head tracking technologies that require additional tools fixed at the user's head. This underlines the need for a development of a real-time and non-intrusive head tracking technology for multiple viewers. An evaluation of different tracking technologies showed that optical tracking (camera based methods) is most promising for the use in display applications.

General Requirements for 3D Display Application Scenarios

Typical 3D display application areas have been identified and the related tracker properties have been specified approximately. These were the number of viewers that could be accommodated, the viewing distance of those viewers, the allowed viewer mobility and the head tracking accuracy and latency. Table T9-1 shows typical 3D display application areas and the related tracker properties.

	No. of viewers	Viewing distance	Viewer mobility	Tracker accuracy	Tracker latency
3D Television	≤4	1m – 3m	+	+	+
Design & Engineering	≤4	50cm – 4m	0	+	-
Information Display	≤4	±2	++	+	++
Luggage Inspection	≤4	30cm – 1,5m	+	+	++
Medical – Diagnosis	1	30-50cm	--	++	-
Medical – Pre-surgery planning	≤4	30cm – 1m	0	+	-
Medical – Training	>1 ≤10	variable, depending on context	variable, depending on context	+	+
Medical – Operating Theatre	>1 ≤4	1m – 5m	+	++	++
Medical – Minimally invasive surgery	1	30cm-50cm	--	0	0
Pseudo 3D Presentation with FogScreen	1 - 2	50cm – 1,5m	++	-	-

Table T9-1. Overview of requirements for different application scenarios

Requirements for FogScreen Display Technology

A demo version of HHI's single-user head tracker has been provided to the FogScreen [2] developers and initial experiments have been made on FogScreen. It works well through the screen, but detailed experiences with 3D coordinates do not yet exist. Tests showed that same technology with some modifications could also be used in association with a user-tracked 3D FogScreen, to create an immaterial, unobtrusive 3D display.

A basic requirement for FogScreen applications has been identified. The head tracking area has to be significantly widened. We start with a small FOV where one camera is enough. Multiple cameras and other ways can overcome the problem. The selection of cameras and adequate adjustments can accomplish the functionality in a FogScreen environment.

Specification of Technical Parameters

Based on the general requirements a set of technical parameters has been specified that can be used for the design of a first software and hardware structure.

- Number of users: up to 4 persons
- mean viewing distance: $A \approx 2 \text{ m}$
- variation of viewing distance: $\Delta A \approx \pm 1 \text{ m}$
- horizontal aperture angle: $\alpha \approx 60^\circ$
- mean viewing height: 1,4 m
- variation of viewing height: $\Delta B \approx \pm 0,6 \text{ m}$
- vertical aperture angle: $\beta \approx 30^\circ$
- Tracking accuracy: x/y-axis $\pm 6 \text{ mm}$
- z-axis $\pm 10 \text{ mm}$
- Latency: 20 – 30 ms
- Tolerable head rotation during use: pitch
 - yaw 20°
 - roll 20°

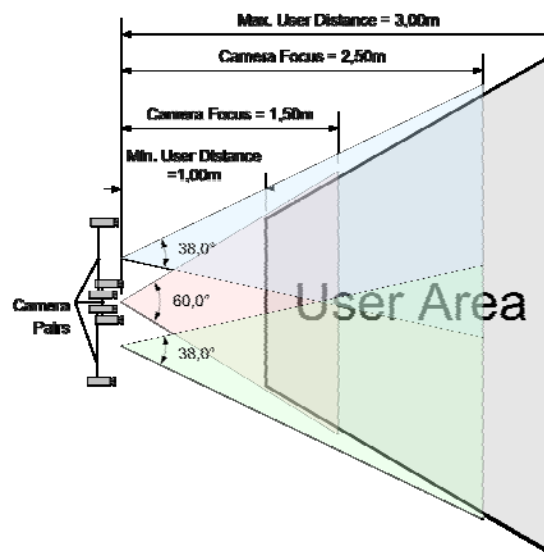

Figure T9-1: Used multi-camera approach with common PAL technology.

Hardware Topology

Several hardware designs have been evaluated. An approach that uses multiple cameras with common (PAL-like) resolution seem appropriate and cost effective (Figure T9-1).

Software Topology of a Multi-User Approach

The large range of different possible application scenarios requires a flexible software design providing a system with high modularity and scalability. The tracking system should support a simple tracking approach with only one camera as well as a complex tracking arrangement with many cameras, a large tracking area and many concurring image processing processes. The application programmer should be able to customize the tracking system regarding the number of cameras including their arrangement, which implies the observed tracking area. The available processing power, the management of multithreading and parallelization and the number and kind of tracked objects should be scalable and easily manageable by the software engineer.

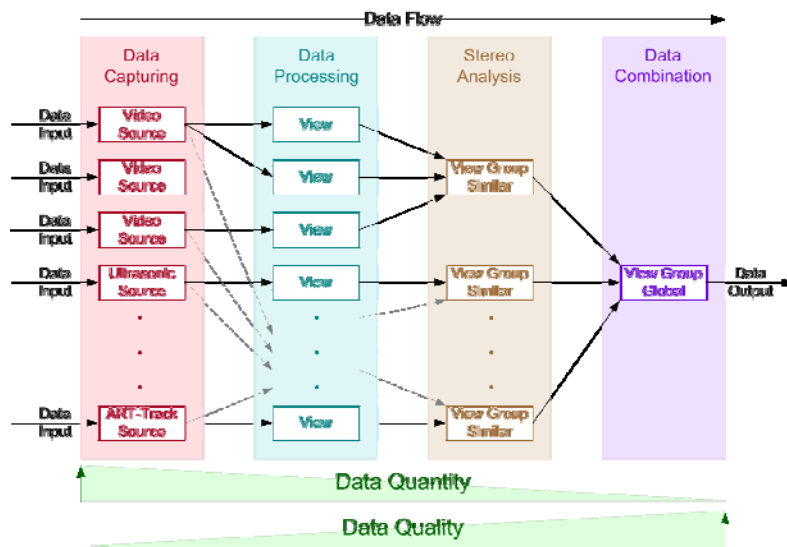

Figure T9-2: The rough structure of the modular concept.

Figure T9-2 shows the basic design of the tracking software. Essentially, it consists of modules responsible for image capturing, image processing, stereo analysis and the final data combination. The figure clarifies the main data flow with its amount and quality. The system works data driven. This is needed to combine data sources with different properties (e.g. frame rate) and assures a processor load as low as possible (in combination with the multithreading approach mentioned above). The data processing is initiated when a data source notifies the availability of data. When the data processing is done, the stereo analysis module is informed. Finally the data combination stage is reached when new stereoscopic data is available. Globally unified data are generated and transferred to the connected applications.

First Realization of a Multi-User Head Tracking Systems

Within the European MUTED project a first multi-user head tracking system has been realized by developers of Fraunhofer HHI. This development is based on the joint evaluations of NoE partners.

*Joint Work with People outwith the NoE*User Trials with a First Multi-User Head Tracking Implementation

For a detailed specification of an eye-tracking system suitable for entertainment and medical applications user trials have been performed. This has been done in primary responsibility of an external partner (TU Eindhoven). The tracker developed by Fraunhofer HHI has been tested and evaluated in different application scenarios. This work focuses mainly on the influence of different lighting conditions and the typical behavior (movements) of the users. The results are currently evaluated. At first glance the trials showed that the camera calibration procedure of the developed tracking technology should be improved. A further deficiency seems to be the lack of robustness and inaccuracy in scenarios with large (> 2.5 m) viewing distances.

Summary and Outlook

In joint work the requirements of a multi-user head tracker for 3DTV display applications have been evaluated and specified. A first set of basic tracker parameters has been acquired and a first hardware and software concept has been developed. Based on the specifications a first multi-user head tracking system has been developed by Fraunhofer HHI. The evaluation of the latest user trials will extend and complete the specifications. Further user trials are planned in the framework of the European MUTED project. A tracked multi-user 3D display will be tested in the medical domain. It is expected that results from the trials can be used for further improvements of the multi-user head tracking technology.

The joint evaluation and specification of multi-user head tracking systems is a basis for developments in the European MUTED project and will also be used in the planned work of the HELIUM3D project [3].

References

1. K. Hopf, P. Chojecki, F. Neumann and D. Przewozny: "Novel User Interaction Technologies in 3D Display Systems", in Digest of Technical Papers of 7th IMID, Volume 7, Book II, pp. 1227-1234, Daegu, Korea, 2007.
2. Rakkolainen, K. Palovuori, "A Walk-thru Screen. IS&T", Spie Electronic Imaging 2002, Proc. of Conference on Projection Displays VIII, pp. 17-22, San Jose, CA, USA, January 23-24, 2002.
3. P. Surman I. Sexton, K. Hopf, W. K. Lee, E. Buckley, G. Jones, R. Bates, "European Research into Head Tracked Autostereoscopic Displays", 3DTV-Conference 2008, Capture, Transmission and Display of 3D Video, 28-30 May 2008, Istanbul, Turkey.

Task 13: Underlying Micro-optical and MEMS Technologies**Evaluation and specification of underlying micro-optical and micro-mechanical technologies for 3D displays**

Participants: KOC, DMU, Bilkent, CLOSPI-BAS

Author: H. Urey

Summary

The purpose of this task was to survey the key underlying micro-optical and micro-mechanical technologies used in holographic, volumetric, and auto-stereoscopic 3D displays. A few of the important micro-optical technologies for 3D displays are microlens arrays, diffractive or holographic optical elements (DOE), Fresnel lenses, and Gaussian super lenses. Dynamic elements, such as those implemented with micro-electro-mechanical systems (MEMS) technology, which can be integrated with micro-optical technologies and SLMs to affect time-multiplexing of multiple views or dynamic scanning/steering of the viewing fields. The technologies mentioned above are briefly reviewed in this report. Both micro-optical components and dynamic MEMS components are key underlying technologies for a number of 3D display technologies, particularly for multi-view and reconfigurable technologies.

1. Micro-optics in 3D Displays.

Micro-optic devices are an effective technology for shaping and influencing light behaviour with very small structures and components that enable its collection, distribution, or modification. Micro-optics has a 10–20 year history and is applied in many fields. It is a key technology to meet the needs of miniaturization, cost reduction, and enhanced performance. It enables various electro-optical methods like beam shaping, optical data storage, optical communication, optical sensors etc. and of course displays. In electronic display systems, micro-optical components bring more flexibility in system design to increase the overall performance, which makes them more appealing also for 3D displays.

a) Microlenses

Microlenses are optical components composed of small lenses, generally with diameters less than a millimetre and often as small as a few micrometers. Diffractive, refractive and graded index (GRIN) microlenses are commercially available. Although GRIN lenses are well suited for imaging the difficult fabrication process severely limits its usage. Diffractive microlenses are generally not well suited for imaging tasks and their focal length and efficiency depend strongly on the wavelength of the light and limit lenses to monochromatic applications [1]. Thus, refractive lenses are mostly preferred for imaging. Reflow and melting resist techniques are applicable to refractive lens production. Structured wavelength filters and aperture arrays are used to improve image contrast by blocking aberrant rays and adapting wavelength spectra. Since packaging and alignment is difficult, manufacturing microlenses on a wafer scale and wafer level packaging approach can be adapted. Microlenses can achieve focusing by a variation of refractive index across the lens (GRIN lenses) or by both a variation in refractive index and by the surface shape. Microlens arrays contain multiple lenses formed in a one-dimensional or two-dimensional array on a supporting substrate. If the individual lenses have circular apertures and do not overlap, they may be placed in a hexagonal array to obtain maximum coverage of the

substrate. However, there will still be gaps between the lenses which can only be reduced by making the microlenses with non-circular apertures.

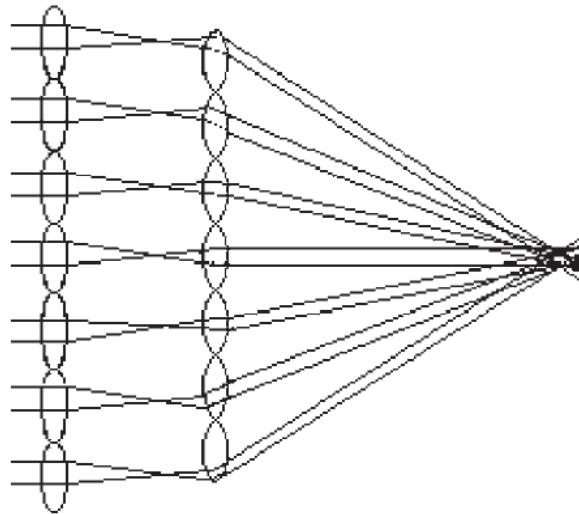

Figure T13-1. Focusing of rays by a superlens [see 2]

As it can be seen in Figure T13-1 microlenses can be used to form an optical system called a “superlens”. A superlens consists of a pair of microlens arrays with a slight difference in pitch. All the light rays passing through a pair of lenses converge to a common point for all channels and the system behaves like a lens. A superlens may consist of two arrays of positive lenses to form Keplerian telescopes or may consist of positive lenses in conjunction with an array of negative lenses to form Galilean telescopes [2].

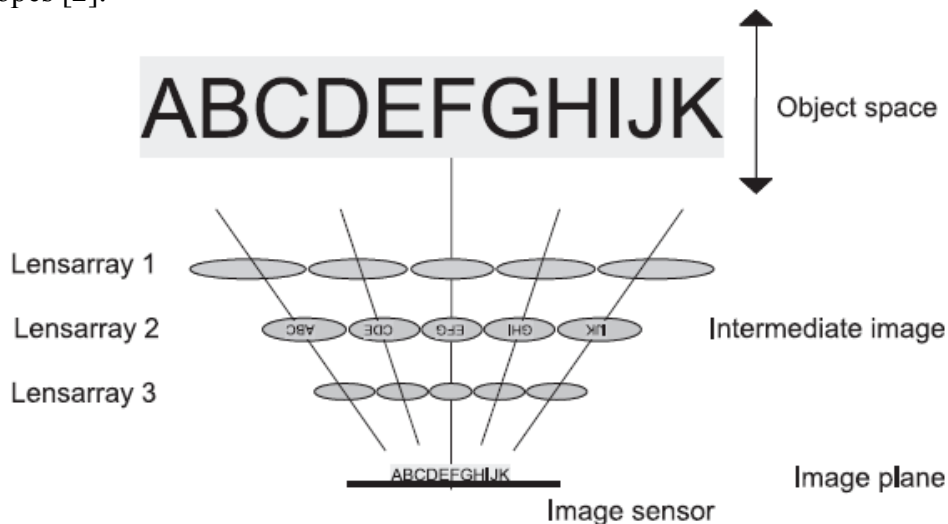

Figure T13-2. Compound eye type imaging system [after 3]

The compound eye consists of three lens arrays with different pitches, which form channels with field lenses and tilted optical axes. Each telescope channel can transmit a certain part of the overall FOV as shown in Figure T13-2 (apposition compound eye), determined by a field stop array in the intermediate image plane at the position of the field lens array or can transmit all FOV (superposition compound eye) depending on the angular spectrum applied to the imaging system [3]. The widths and

positions of the field apertures determine the amount of overlap and spatial annexation of the elemental images. Anamorphic lenses with elliptical lens bases can correct for astigmatism caused by oblique incidence, and help to keep a constant projected aperture size.

b) Fresnel and Gaussian Lenses

The Fresnel lens was originally developed for lighthouses, which enables the construction of large aperture and short focal length systems without the weight and volume of material required in a conventional lens. Compared to conventional lenses, the Fresnel lens is much thinner, thus passing more light and allowing visibility over much longer distances. The Fresnel lens reduces the amount of material required compared to a conventional spherical lens by breaking the lens into a set of concentric annular sections known as Fresnel zones.

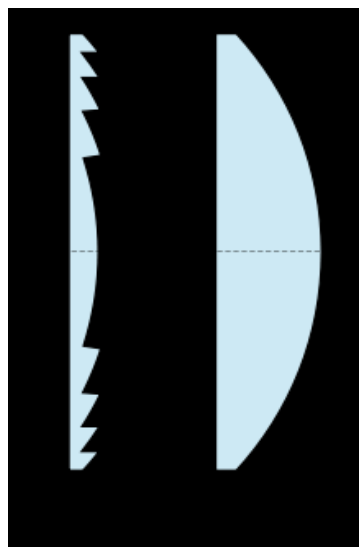

Figure T13-3. Cross section of a Fresnel and conventional plano-convex lens of equivalent power

c) Diffraction Gratings

A diffraction grating is an optical device used to disperse light into a spectrum (Figure T13-4) [4]. It is ruled with closely-spaced, fine, parallel grooves, typically several thousand per cm, that produce interference patterns in a way that separates all the components of the incoming light. The diffraction pattern produced by the grating is described by the equation:

$$m \lambda = d \sin \theta$$

where m is the order number, λ is a selected wavelength, d is the spacing of the grooves, and θ is the angle of incidence of light. The diffraction grating is an immensely useful tool for the separation of the spectral lines associated with atomic transitions. It acts as a "super prism", separating the different colours of light much more than the dispersion effect in a prism.

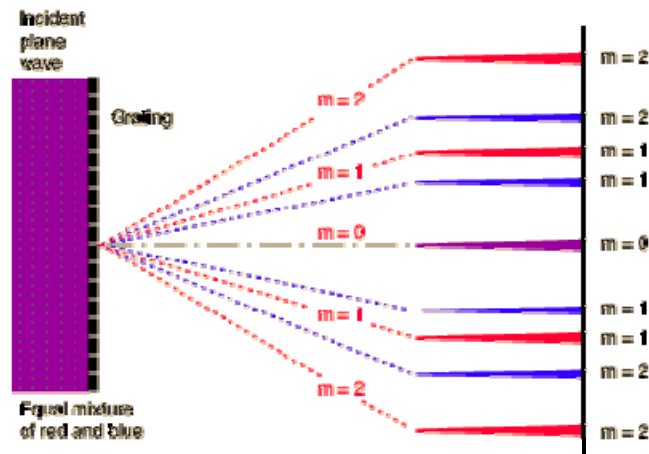

Figure T13-4: Diffraction grating

d) Holographic elements [5].

An optical system can be thought of as a device that transforms input wavefronts into output wavefronts. The class of transformations that link the output wavefronts to the input in refractive-reflective optical systems is quite limited. For example, it is not possible to design a refractive-reflective optical system for which the output wavefront is a three-dimensional image of, for example, a teapot when the input wavefront is a collimated beam. This particular input-output transformation can, however, be realized by using a hologram. Holograms can also be made to have transfer functions that are desirable in optical systems, in which case they are referred to as holographic optical elements (HOE's). The optical transfer function of a HOE is based on diffraction, and therefore the characteristics of these elements are highly wavelength dependent. Consequently, HOE's are useful, and sometimes indispensable, components of optical systems when the source is monochromatic or when a wavelength-dependent system is desired. Given an arbitrary input wave front, an HOE can be designed, in principle, to transform this input wave front into an arbitrary output wave front. In such a situation, the required HOE recording beams are most likely produced by computer-generated holograms in conjunction with conventional refractive and reflective optical elements.

e) Review of fabrication technologies for micro-optics [see 1]

The most promising manufacturing technique for refractive microlens arrays is the reflow or melting resist technique. Photoresist is micro-structured by photolithography and melted. The lens profile is formed by surface tension during the melting. The melted resist lens serves as a master for subsequent transfer processes like reactive ion etching or replication in plastic. Aspheric lens profiles are obtained by varying the etch parameters during the reactive ion etching transfer.

Packaging and alignment of miniaturized lens systems is a rather difficult task. Every micro-optical component has to be aligned according to three lateral and three rotational degrees of freedom. For micro-optics, standard "classical" mounting is not practical and too expensive. The preferred solution is manufacturing of microlenses on a wafer-scale and a wafer-level packaging approach for mounting. A mask aligner aligns a stack of planar wafers containing both image sensors and optics. The different layers are bonded together by using, e.g., UV-curing epoxy, thermal and fusion bonding or thick-film solder glass bonding. A subsequent dicing step separates the

wafer stack into the individual systems or modules. This method allows a cost-efficient mounting of some hundreds of micro-cameras in one step.

2. 3D Displays using Dynamic Components

The number of different views a display can provide and the number of different viewers who can view the display simultaneously are important quality parameters for 3D display systems. The increase in the number of either different viewers or different views needs more complex optical system design. The adaptation of some current autostereoscopic technologies such as lenticular sheets or parallax barriers to provide larger number of multi views results in reduced quality (e.g. reduced resolution and increased image quality difference between different views). Time-multiplexed systems with dynamic components can solve the problem of displaying the increasing amount of information. In this way, either different views or the pixels in each view are displayed time-sequentially.

For time-sequential display of different views, a high speed projector capable of projecting a frame of each multiview in a single frame time of a conventional projector is needed [6]. In order to direct the different views to different viewing regions, the entrance pupil of the projector objective is divided into a number of segments equal to the number of multiviews. During a single time frame interval of the projector only a single segment is active (Figure T13-5). To realise the functionality of segmenting and switching between different segments, high speed LC shutters are used. In order to project n different views, the LC shutter with n vertical stripes of equal width to provide horizontal parallax is used. The LC shutter, the switching mechanism and the projector works at a frame rate of $60n$ Hz. For n of 8, each frame of a single view is projected for 2.08 ms every 16.7 ms. The necessity for such high switching frequencies both for the projector and the LC shutter requires consideration of available spatial light modulator (SLM) technologies. Today's available projector technologies with such high speeds are the cathode ray tube (CRT), the digital micro mirror device (DMD) and ferroelectric liquid crystal displays (FLCD) or grating light valves (GLV).

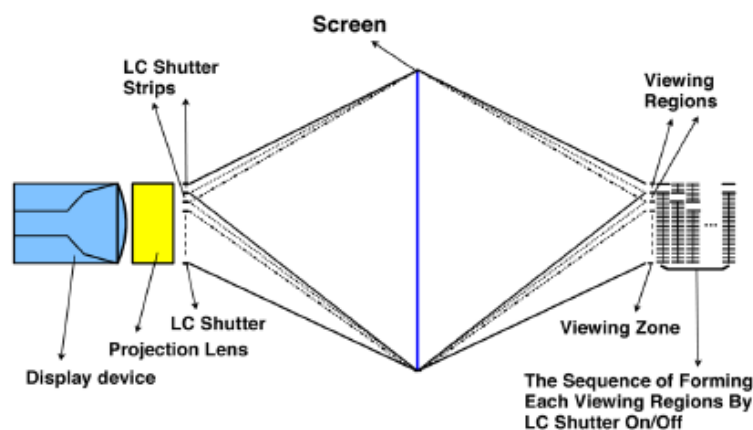

Figure T13-5: 3D Display using time multiplexing technology [after 6]

Digital Micro Mirror Devices (DMD): DMD's consists of a 2D array of independently controllable aluminium micromirrors with pitches of $16\ \mu\text{m}$ placed on hinges over a CMOS static RAM chip. The mirrors are tilted either ON or OFF with

tens of microseconds switching time. High reflectance efficiency provides an advantage to DMDs when compared to the LCD technologies [7].

Ferro Electric Liquid Crystals (FLCD): Liquid Crystal SLMs are electrically addressable devices with a similar driving mechanism used in LCD TVs. The ferroelectric liquid crystals are nematic type LCs in the smectic C type arrangement. In the smectic C type arrangement, the liquid crystal molecules are arranged in different molecule layers and each molecule layer is tilted with a specific angle relative to the previous layer. This spiral structure of the smectic C type arrangement allows the fast switching in the range of tens of microseconds.

Grating Light Valves (GLV): The GLV employs a novel micro mechanical phase grating technology using parallel rows of reflecting ribbons. By controlling the relative position of the ribbons incident light is diffracted and using pulse width modulation (PWM), different gray scales can be achieved. This technology has very fast switching frequencies at the range of tens of nanoseconds [8].

The Cambridge time-sequential display, which uses the same time-multiplexing principals, can be considered in terms of two different optical systems. The first one is the compound image transfer stage, projecting an image of the CRT onto a Fresnel lens and a Fresnel lens imaging the synchronized LC shutter to the proper viewing region [9].

The above time-multiplexing concept is also realised using scanning spherical mirrors or scanning flat mirrors together with field lenses. The multi view images are prepared time sequentially by segmenting the input pupil of the projector by a scanning mechanism. The images are displayed through a projection lens onto the scanning spherical mirror, which directs the views onto the different viewing regions. In both mechanisms, scanning mirror and scanning segments, sliding aperture mechanisms work in synchronization. In the latter system, displaying the pixels in each view time sequentially, the general methodology is forming a multiview pixel which is a combination of same order pixels of different views. The multiview pixel is then scanned in horizontal and vertical directions to constitute the 2D image. In one of the technologies using this technique (focused light array - FLA), a laser diode array is placed on a horizontal arc with a specific angular distance (0.5°) to generate the multi view pixel [10]. The independently controllable light sources are focused to a single point, to the centre of the horizontal arc, which is the multi view pixel. The focused light is collimated and scanned in vertical and horizontal directions with, for example, polygon scanners. The collimated 2D scanned light is focused to the focal plane of an imaging lens where it is vertically diffused to increase the field of view (FOV) in the vertical direction as illustrated in Figure T13-6. Such a system, known as super multiview display, is capable of providing more than one view to both eyes of the viewer simultaneously.

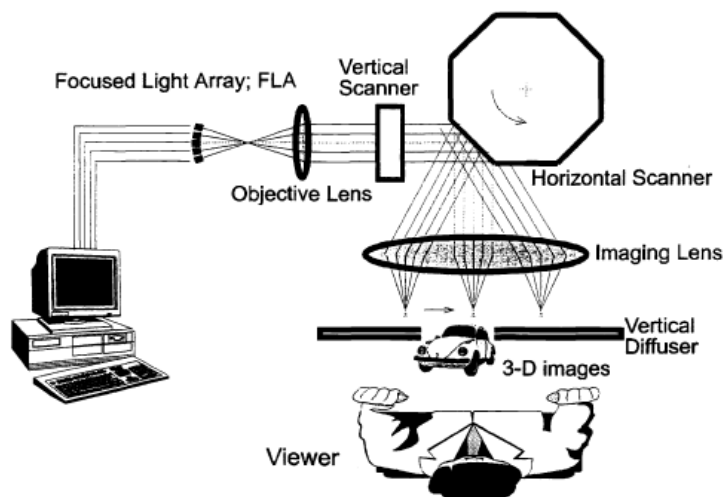

Figure T13-6 Working principle of the FLA System [after 10]

Dynamic optical components are also used in head tracking displays. In multi-view 3D displays using optical plates, such as lenticular sheet, parallax barrier or micro lens arrays, to form the different viewing regions, the relative shift of the optical plate and the light sources result in the shift of the viewing regions. The shift of the optical plate is realised by using different mechanical systems such as piezo-electrical devices.

References

1. R. Völkel, M. Eisner, K.J. Weible, "Miniaturized imaging systems," *Microelectronic Engineering* 67–68 (2003) 461–472
2. H. R. Fallah, A. Karimzadeh, "Design and simulation of a high-resolution superposition compound eye," *Journal of Modern Optics* Vol. 54, No. 1, 10 January 2007, 67–76
3. J. Duparre, P. Schreiber, A. Matthes, E. P. Severin, A. Brauer, A. Tünnermann, "Microoptical telescope compound eye," 7 February 2005 / Vol. 13, No.3 / *Optics Express* 889
4. H-P. D. Shieh, Y-P. Huang, K-W. Chien, "Micro-Optics for Liquid Crystal Displays Applications," *Invited Paper IEEE/OSA Journal of Display Technology*, Vol. 1, No. 1, September 2005
5. K. A. Winick, J. R. Fienup, "Optimum holographic elements recorded with nonspherical wave fronts," *J. Opt. Soc. Am.*/Vol. 73, No. 2/February 1983
6. J. Y. Son, B. Javidi, "Three Dimensional Imaging Methods Based on Multiview Images", *IEEE Journal of Display Technology*, vol. 1, no. 1, pp. 125-140, September 2005
7. P. Benzie, J. Watson, P. Surman, I. Rakkolainen, K. Hopf, H. Urey, V. Sainov, C. Von Kopylow, "A survey of 3DTV Displays, Techniques and Technologies", *IEEE Transactions on Circuits and Systems for Video Technology* , vol.17, no. 11, Nov 2007
8. D.M. Bloom, "The Grating Light Valve: revolutionizing display technology"
9. N. A. Dodgson, J. R. Moore, S. R. Lang, G. Martin, P. Canepa, "A Time-Sequential Multi Projector Autostereoscopic Display", *Journal of the Society for Information Display* 8(2), 2000, pp. 169–176
10. Y. Kajiki, H. Yoshikowa, T. Honda, "Auto Stereoscopic 3-D Video Display Using Multiple Light Beams with Scanning", *IEEE Transactions on Circuits and Systems for Video Technology*, Vol. 10, No. 2, March 2000

2.3 Human Factors (Tasks 8 and 10)

As has often been said, the human comfort and acceptability is crucial for the acceptance of 3D as a TV medium or indeed in any area of application. Many factors influence the acceptance of 3D by a user. Some of these factors included convergence, motion parallax, interactivity, comfort and colour. Many of these are discussed here as well as means of monitoring and quantitatively evaluating their impact. Whether or not 3D TV and vision does break into our lives depends dramatically on these problems being overcome.

Tasks 8 & 10: Human Factors**Evaluation of human factors related to autostereo and holographic displays**

Participants: Bilkent, BIAS, DMU, FogS, ITI-CERTH, KU, METU, Momentum, Plzen, UNIABDN, TUT

Investigation of interactivity of 3D application systems and their usability, together with related human factors

Participants: UIL, TUT, TUB

Authors: D. Strohmeier and S. Jumisko-Pyykkö

This is a joint report covering both Tasks 8 and 10.

The work conducted

Human factors, related to novel techniques and applications, are a broad and important topic. The possible themes under the topic, with high relevance also to 3DTV research may cover user-centric design of new applications including the interaction and their evaluation, perceptual quality evaluation experiments, ergonomic aspects and social impacts of new techniques.

Tasks 8 and 10 have broadly approached the human factors related to displays and multimodal 3D systems. The conducted research works within both tasks were strongly overlapping and therefore to make a coherent overview to the work they are presented together here. There have been five main aspects in these studies:

- Divided attention and multimodal interaction
- 2D and 3D perception and interaction
- Development of a test bed for performing interactive audiovisual subjective assessments
- Development of applications and their evaluation on immaterial projection screen
- Development of evaluation methods to gain higher ecological validity for quality evaluation experiments and to understand the meaning of perceived quality in depth.

Divided attention and multimodal interaction

Examination of divided attention and its impact on multimodal interaction and quality requirements has been one of the most studied topics within the work of human factors. The work started by Reiter & Jumisko-Pyykkö [1] who studied the impact of divided attention on requirements of audiovisual quality. Many of today's audiovisual application systems offer some kind of interactivity. Yet, quality assessments of these systems are often performed without taking into account the possible effects of divided attention caused by interaction or user task. We present a subjective assessment performed among 40 test subjects to investigate the impact of divided attention on the perception of audiovisual quality in interactive application systems. Test subjects were asked to rate the overall perceived audiovisual quality in an interactive 3D scene with varying degrees of interactive tasks to be performed by the subjects. As a result it was found that the experienced overall quality did not vary with the degree of interaction. The results of the study made clear that in the case

where interactivity is offered in an audiovisual application, it is not generally possible to technically lower the signal quality without perceptual effects.

Further, Jumisko-Pyykkö, Reiter & Weigel [2] have approached the same topic of impact of interaction on audiovisual quality and introduced the data-collection method for gathering the data qualitatively. Subjective audiovisual quality is typically phrased via quantitative experiments as a preference order of predefined variables. However, the produced quality is not in 1:1 ratio to the perceived quality because of human active interpretation and complexity of multimodality in perceptual processes. This study presents qualitatively collected audiovisual quality experience factors and connects these expressions to quantitative results in order to understand the relation between produced and experienced quality in the context of interactive audiovisual application systems.

This work focused on the effect that interaction with an audiovisual application or scene might have impact on the perceived overall quality. Here, the general assumption was that by offering an attractive interactive content or by assigning the user a challenging task, the user would become more involved and thus he would experience a subjectively higher overall quality. As has been shown, this is not generally the case. However, when both task and main varying (or salient) quality attribute were located in the same modality, such an effect could be substantiated. Apparently, inner-modal influence is significantly greater than cross-modal influence. This is also suggested by the common theories of capacity limits of the processes of human attention and working memory.

Reiter and Weitzel [3] have examined the influence of interaction on perceived quality in audiovisual applications and evaluated the cross-modal influence. This paper presents a subjective assessment among 32 test subjects performed to investigate the question of possible cross-modal division of attention in interactive audiovisual application systems. They give an overview on recent related research, and describe in detail the experimental setup, the procedure and the analysis of the data obtained. As a result, the experiment described verifies that interaction or task can have an influence upon the perceived audio quality, even if the interaction/task is performed in another modality.

Reiter and his group [4, 5] have also studied the impact of an n-back working memory task on the requirements of auditory quality. This paper describes an experiment related to human audiovisual perception under different degrees of distraction. In an audiovisual subjective assessment subjects were asked to rate an auditory parameter while being distracted with an n-back working memory task. Unlike in previously published experiments, both rating and task took place in the same modality. The analysis of the data obtained indicates that the precision with which auditory parameters can be rated by humans is dependent on the degree of distraction in the same modality.

Reiter & Weitzel [3] have worked further with the topic by using n-back working memory task while studying the requirements for multimodal quality. For interactive audiovisual applications running on devices with limited computational power it is desirable to know which of the stimuli to be rendered in an audio visual room simulation have the greatest impact upon the perceived quality of the system. Reiter

and Weitzel conducted experiments to determine the effect of interaction upon the precision with which test subjects are able to discriminate between different parameter values of auditory attributes. The paper details one of these experiments and compares different approaches for the analysis of the obtained data. The results show a noticeable bias towards faulty ratings during the involvement in a task, although the analyses using significance tests do not completely confirm this effect.

To sum up, this showed that also cross-modal influence of interaction is possible when stimuli and interaction are carefully balanced. At this time it is not possible to determine or quantify that balance a priori. However, some of the influence factors that contribute to this balance have been identified in a salience model for interactive audiovisual applications of moderate complexity. Now, these influence factors need to be quantified.

2D and 3D perception and interaction

To understand the characteristics of 2D and 3D video perception, Strohmeier [6] focused on the development of new subjective assessment methods. The quality of the user's perception of audiovisual stimuli is based on the combination of different sensory information. Additionally, quality perception is influenced by additional factors like previous experience of the user with the system or his expectations about new, unknown systems. Recent, standardized methods are not able to include these additional factors to the analysis as they are mainly based on quantitative approaches. Strohmeier adapted methods from food science to use them for audiovisual quality assessments. Following the theory of mixed method research, it is now possible to combine quantitative and qualitative data in the stage of analysis. Additionally to quantitative data, test participants develop individual experienced quality factors that describe what the test participant really perceived. This method now allows for further tests on audiovisual quality perception to better understand its underlying processes impact on quality interpretation.

Furthermore, to understand the experience between audiovisual 3D experience, Strohmeier & Jumisko-Pyykkö [7] examined an optimum loudspeaker set-up for audiovisual environments using a 15" autostereoscopic display to present video. By varying the number of loudspeakers and their distance from the listening point, we performed subjective assessment tests on four different set-ups with 32 participants. We measured simulator sickness to examine possible influencing side effects of visual presentation. As a test environment, we chose the MPEG-4 based audiovisual IAVAS player and content creation was carried out using virtual rooms. Our results show that four loudspeakers in a distance of one meter from the listener offer the most pleasant experience of audiovisual quality and the result is not significantly impacted by visual discomfort.

Bastanlar et al. [8] have studied feeling of presence, object recognition and navigation performance between 2D and 3D visual environments. In this work, effects of stereoscopic view on object recognition and navigation performance of the participants are examined in an indoor Desktop Virtual Reality Environment, which is a two-floor virtual museum having different floor plans and 3D object models inside. This environment is used in two different experimental settings: 1) color-multiplex stereoscopic 3D viewing is provided by coloured eye-wear, 2) regular 2D viewing. After the experiment, participants filled a questionnaire that inquires their feeling of

presence, their tendency to be immersed and their performance on object recognition and navigation in the environment. Two groups (3D and 2D), each having 5 participants, with equal tendency are formed according to the answers of 'tendency' part, and the rest is evaluated to examine the effects of stereoscopic view. Contrary to our expectations, results show no significant difference between 3D and 2D groups both on feeling of presence and object recognition/navigation performance.

Test bed for performing interactive audiovisual assessments

Closely related to the attention and multimodal quality studies, Reiter [9] also describes a system for performing subjective quality assessments of interactive A/V content. Room acoustic simulations are very cost-intensive in terms of computing power, which makes interactive real time applications especially demanding. Due to the limited amount of computing power available in these systems, the simulation process has to be simplified. It is especially interesting to investigate the amount of simplification that goes unnoticed regarding the perceived overall quality of such audio-visual applications.

The assessment system created consists of three main parts: the I3D MPEG-4 based interactive audiovisual scene renderer, the input device for test subject's haptic feedback, and the SALT logging and exporting tool for the obtained data. All three elements provide clearly defined interfaces. They could be exchanged with other elements providing the same or extended functionality without provoking malfunctions to the system as a whole.

The I3D's audio functionality, namely the TANGA real-time rendering, is the first modular audio engine available in an MPEG-4 player. The specifications follow the needs of today's audiovisual scene representation paradigms. The room acoustic simulation features that include a simplified image source model and the so-called Perceptual Approach are unique. The experiments performed have shown that in the simplified image source model, a careful matching of Early Reflections (ER) and Diffuse Reverberation (DR) parts is necessary to produce a convincing overall room acoustic impression. This is more important than the sheer number or order of image sources contributing to the ERs. Although the computational load is comparatively high, the image source model based computation allows for immanent changes in the ER pattern. These changes (or the lack of) were clearly perceived by test subjects in the audiovisual assessments performed.

Occlusion and obstruction effects have been identified to be very important for a convincing audiovisual impression. Unfortunately, the methods that exist for the detection of obstruction are either very coarse (e.g. using BoundingSpheres) or computationally expensive. For rectangular-shaped rooms without large obstructing objects the image source method provides very useful results. For more complex rooms or systems of (acoustically) interconnected rooms, the beam tracing method has very high potential.

The haptic Input Device as a means of collecting quality feedback from test subjects has proven to work efficiently and flawlessly. Test subjects were, according to their own estimation, able to concentrate fully on the audiovisual percepts presented in the assessments. Especially for sequences of single-stimulus items (ACR) this was

observed. The usage of the Input Device was regarded as straight-forward and intuitive.

The JAVA-based Subjective Assessment Logging Tool (SALT) was used extensively to record the test subjects' ratings and all other events (high scores, presentation order of items and trials, subject related data) during the assessments. Its GUI is straightforward and helps to prepare different types of assessments. The fact that complete assessment setups can be saved and restored at a later time has considerably helped in performing assessments in a lab that was frequently used by other experimenters in between the test sessions.

Together with the Input Device, SALT for the first time provides an integrated hardware/software system for easy collection, unscrambling² and export of assessment data. It is not limited to the field of audiovisual assessments, but can also be applied in traditional unimodal quality tests.

Interaction with immaterial projection screen

To create new techniques and applications appealing to users, filling their functional and ergonomic requirements and needs they are necessary to take in part to development process as early as possible. Rakkolainen et al [10] published developed system for mid-air display for physical exercise and gaming purposes and its preliminary user-evaluation. We present some possibilities and our experiments with the “immaterial” walk-through FogScreen for gaming and physical exercise. We use real-time 3D graphics and interactivity for creating visually and physically compelling games with the immaterial screens. An immaterial projection screen has many advantages for physical exercise, games and other activities. It is visually intriguing and can also be made two-sided so that the opposing gamers on each side see both their side of the screen and each other through it, and can even walk through it. The immaterial nature of the screen helps also on maintenance, as the screen is unbreakable and stays always clean. The initial results show that the audience stayed with the game over extended periods. The overall comments of the gaming and physical exercise environment were positive and it was generally assessed to be captivating and inspiring.

Jumisko-Pyykkö et al. [11] have conducted the first systematic study to evaluate the game experience using immaterial projection screen. They studied children's game experiences between physical gaming on the immaterial FogScreen and a mouse-based PC gaming. The systematic game evaluation experiment was conducted with 20 children. Game experiences were measured quantitatively using a children-friendly flow questionnaire and a qualitative interview for gathering playing impressions. The results showed that FogScreen provided novel gaming experience, was funnier and children enjoyed about its naturalness and possibilities to move compared to PC setup. However, the interaction with the FogScreen set-up was harder, providing a lower level of playability and controllability than the PC set-up.

Rakkolainen & Lygmayr [12] have also investigated experiences of interactive advertisements presented on immaterial screen. We present some of our experiments

² The term “scrambled data” refers to items that are presented in random order. The related ratings are also stored in the order of presentation, and need to be “unscrambled” or sorted before data is exported.

with the “immaterial” walk-through FogScreen for advertising. We use interactivity for creating visually compelling advertisements with the immaterial screens in mid-air. An immaterial projection screen has many advantages for advertisements and other applications. It is visually intriguing and can also be made two-sided so that the opposing viewers on each side see both their side of the screen and each other through it, and can even walk through it. The screen is unbreakable and stays always clean. Our results show that the audience stayed with the walk-through advertisement over extended periods of time and the overall comments were positive. It was generally assessed to be very captivating and inspiring. However, the whole concept of immaterial, interactive mid-air display is so new that viewers would have needed more instructions for using it, like for example a text in mid-air saying “touch me” or such. This underlines the importance of well-designed content with any media platform.

DiVerdi et al. [13] have investigated an immaterial pseudo-3D display with 3D interaction. We present a novel walk-through pseudo-3D display, which enables 3D interaction and interesting possibilities for advanced user interface designs. Our work is based on the patented FogScreen, an “immaterial” indoor 2D projection screen which enables high-quality projected images in free space. We extend the basic 2D FogScreen setup with stereoscopic imagery and two-sidedness, in addition to the use of head tracking to provide correct perspective 3D rendering for a single user. We also add support for 2D and 3D interaction for multiple users with the objects on the screen, via a number of wireless input technologies that let us experiment with interaction with or without encumbering devices. We evaluate the usability of these interaction techniques by observing non-expert use in real set-tings to quantify the effects they have on 3D perception. The result is a wall-sized, immaterial pseudo-3D display that enables engaging 3D visuals with intriguing 3D interaction.

Evaluation/Assessment Methods

The assessments performed have shown that the existing recommendations issued by the international bodies of ITU, EBU, AES and IEC provide basic guidelines that can be transferred to the bimodal case. This is true for all recommendations related to the test setup itself and the test methodologies to use. Yet, it is important to note that the focus of these recommendations is on the evaluation of perceived quality of simple commercial systems. It is therefore necessary to specify the type of assessment to be performed before blindly following any such recommendation.

Also, the existing recommendations stem from a period in which such commercial systems did not (or only to a very limited degree) provide means of interaction with a user. None of the recommendations suggests how to consider and include interaction possibilities in the course of evaluation of such systems. That there is an effect of interaction (or, more precisely, of task) upon the perceived quality has been shown in this work. Therefore, it would be favourable if guidelines for the evaluation of application-specific interaction features existed. Yet, it remains unclear how a generalized set of recommendations could cover the whole field.

What is clearly missing in the existing recommendations is a meaningful set of factors resulting to audiovisual quality. Nowadays, only little work has been done to understand quality in a broader sense. This broader view compromises user’s characteristics, task-on-hand, content and context of use.

The Mixed Method approach outlined in Strohmeier [6] needs further evaluation. It consists of a combination of Absolute Category Rating (ACR) and Internal Preference Mapping (IPM) / Principal Components Analysis (PCA) with Free Choice Profiling (FCP) and Generalized Procrustes Analysis (GPA) by means of an External Preference Mapping (EPM) / Partial Least Square regression (PLS). Two promising experiments have been performed using this methodology, but a number of issues remain open that need further research: especially the questions of validity and reliability of the method call for further examination before it can be accepted as a new approach in the assessment of perceived audiovisual quality.

The methodological issues were touched in many points within the current task. Interactive tasks trying to follow the actual use of application were introduced parallel to passive quality evaluation tasks [1, 3, 4, 5]. Parallel to traditional quantitative data-collection in subjective quality measures resulting the preference order of comparisons, qualitative measures of impressions of quality are strongly raising [2, 6, 11]. In the latest stage, the aim to combine these approaches would be beneficial when aiming to understand the produced quality [6]; the method can be applied in various fields from quality evaluation to interactive applications.

Other related work

DMU have been collaborating with the National Physical Laboratory (NPL) on trials to determine the effect of crosstalk on simulated medical tasks. The equipment used is a Helmholtz stereoscope that has zero crosstalk as two LCDs are viewed by mirrors via two completely separate optical paths. Controlled crosstalk is introduced into the images through two video mixers. Tasks are performed by viewing the task region with images from a pair of cameras. Initial trials have been carried out with NPL staff and in the next phase of the work the subjects will be surgeons at St Mary's Hospital.

The HELIUM3D FP7 proposal for a laser-based head tracking 3D display has been successful. The display incorporates a fast 2D light valve, a linear SLM, a MEMS scanner, a superlens screen and a multi target head tracker but does not require an LCD. The display will operate in two modes: the far field mode for applications such as gaming and television and the near field mode for single user task performance. In the near field mode users will be able to carry out tasks within the actual volume of the image. This poses particular human factors problems as the user must be within arm length of the virtual displayed object. This can lead to large accommodation / convergence rivalry and the effects of this will be investigated within the project.

In broader viewpoint, knowledge of nowadays consumer expectations, thoughts for 3DTV's mass consumption, its novelty, potential application and markets summarized from the viewpoint of technical professionals by Onural & Ozaktas [14]. The informally collected data from online discussions encompassed consumer expectations and behaviour, including current perceptions of three-dimensional television (3DTV), its potential for novelty and mass consumption, and other consumer and non-consumer applications and markets for the technology. Most participants in these discussions were technical professionals or academicians with backgrounds in engineering and science, who were members of the Network of Excellence. These discussions serve as an insider record of the ruminations of the developers of a technology about its implications, during an intermediate stage of its

development. It will certainly be interesting to consider these in retrospect ten or twenty years from now.

Summary

- The work of human factors is important for novel techniques and applications to ensure that they fill the user's requirements and needs and make sure that certain ergonomic level is reached. Significant parts of the work focused on examining impact of divided attention on requirements of perceived multimodal quality in order to explore new ways to optimize the produced quality. The main results have shown that divided attention between quality evaluation task and simple visual-motor task does not have impact or have only little impact on perceived audiovisual quality when the highest impacting variable is located in audio modality and the parallel task requires the effort from visual sense. These results show that the information processing is separated between the senses in easy parallel tasks and highlights that there are challenges to lower the produced quality without perceptual effects. These results show the high agreement with the fundamental work done in the psychology about attention and short-term memory [ADD]. Even though these studies show only a piece of possibilities to compromise the multimodal quality, they illustrate the preliminary movements towards consumer or user-oriented quality evaluation scheme which potentiality cannot be doubted in the field of 3DTV applications.
- The work to understand the 2D and 3D perception and interaction is relatively limited in the project. The results have shown both similarities and differences among these and between these.
- The application development, evaluation work and interaction development around the immaterial projection screen have resulted novel environment and novel user-studies in the field. Further studies may pay more attention on formal evaluation of the developed techniques with users and apply user-centred design in the design process of the applications.
- The methodological work is clearly moving towards consumer or user-oriented quality evaluation scheme. In the developed work, the user or evaluators' activity on the level of task has been recognized and strong drive is towards multidimensional, qualitative and quantitative or mixed method in multimodal quality evaluation tests. This approach can lead to the deeper understanding of the success and challenging factors in 3D applications and systems. The main challenges for further studies are to find the methods to study impact of real or assumed end-user's task, contents and contexts, and to select the tasks, contents and contexts according to real or assumed end-user's task, contents and contexts in order to do quality optimization in user-centred way.

Milestones and Breakthroughs

- Various aspects of impact of divided attention on multimodal interaction have been studied. Most notably, capacity limits in human multimodal perception make approaches feasible that rely on highlighting salient features of a multimodal presentation, while at the same time downgrading the simulation accuracy / simulation depth of those features that are less salient. Interactivity has been found to be one of the key factors to determine saliency: whenever interaction is offered by an application, this attracts the human attention towards the interaction, providing a good indicator of current focus and saliency.

- A test bed for audiovisual assessments has been created, verified and put to use. The assessment system created consists of three main parts: the I3D MPEG-4 based interactive audiovisual scene renderer, the Input Device for test subject's haptic feedback, and the SALT logging and exporting tool for the obtained data. All three elements provide clearly defined interfaces.
- The 2D and 3D perception and interaction has been studied.
- The application development, evaluation work and interaction development around the immaterial projection screen.
- Quantitative and qualitative, and mixed method approach for examining quality preferences and impressions have been introduced.

What technology/science roadblocks are preventing development?

- Relatively narrow multidisciplinary collaboration. The collaboration would facilitate broadening the understanding of human behaviour and multimodal perception. It could help also people working on the side of engineering sciences to contribute for building up the fundamental work on human perceptual processes. In addition, user-centered design would be necessary to apply to avoid naive failures in the development of novel 3D multimedia products.
- The available test materials for 3D audiovisual experiments are very limited, especially from the side of visual stimuli. This prevents designing of the high-quality experiments.
- Methodological guidelines for the practitioners for conducting multimodal quality evaluation experiments are limited as well as the standardization activities around these topics. Moreover, the user- or consumer-oriented quality evaluation guidelines would help the practitioners to sketch the quality from the viewpoint of end-products more broadly – not only as an isolated aspect.

References

1. Reiter, U. and Jumisko-Pyykkö, S.: Watch, Press and Catch - Impact of Divided Attention on Requirements of Audiovisual Quality, 12th International Conference on Human-Computer Interaction, HCI2007, Beijing, PR China, July 22-27, 2007
2. Jumisko-Pyykkö, S. , Reiter, U., Weigel, C.: Produced Quality is not Perceived Quality - a Qualitative Approach to Overall Audiovisual Quality, Proceedings of the 3DTV Conference, Kos Island, Greece, May 7-9, 2007
3. Reiter, U, Weitzel, M.: Influence of Interaction on Perceived Quality in Audiovisual Applications: Evaluation of Cross-Modal Influence, Proceedings of the 13th International Conference on Auditory Displays (ICAD), Montreal, Canada, June 26-29, 2007
4. Reiter, U.; Weitzel, M.; Cao, S.: Influence of Interaction on Perceived Quality in Audio Visual Applications: Subjective Assessment with n-Back Working Memory Task, Proceedings of the AES 30th International Conference on Intelligent Audio Environments, Saariselkä, Finland, March 15-17, 2007
5. Reiter, U.; Weitzel, M.: Influence of Interaction on Perceived Quality in Audio Visual Applications: Subjective Assessment with n-Back Working Memory Task, II, Proceedings of the AES 122nd Convention, Vienna, Austria, May 5-8, 2007
6. Strohmeier, D.: "Analyzing Humans' Perception of 2D vs. 3D in Audiovisual Application: A mixed method approach", Master thesis, Technische Universität Ilmenau, Germany, 2007
7. Strohmeier, D. & Jumisko-Pyykkö, S. How does my 3D video sound like? - Impact of loudspeaker set-ups on audiovisual quality on mid-sized autostereoscopic display, Proceedings of second 3DTV Conference, IEEE, 2008
8. Bastanlar, Y., Canturk, D., Karacan, H. Effects of Color-Multiplex Stereoscopic View on Memory and Navigation Proceedings of the 3DTV Conference, Kos Island, Greece, May 7-9, 2007
9. Reiter, U. A System for Performing Subjective Quality Assessments of Interactive A/V Content (System für die Durchführung von subjektiven Wahrnehmungstests interaktiver A/V-Inhalte). Proceedings of 24th Tonmeistertagung - VDT International Convention, November 2006

10. Rakkolainen, I., Erdem, T., Utku, B., Erdem, Ç. Özkan, M. Mid-air Display for Physical Exercise and Gaming. Proceedings of the 3DTV Conference, Kos Island, Greece, May 7-9, 2007
11. Jumisko-Pyykkö, S., Hellsten, S., Weitzel, M., Rakkolainen, I. Children's game experiences in different settings. Proceedings of second 3DTV Conference, IEEE, 2008
12. Rakkolainen, I. and Lugmayr, A. Immaterial Display for Interactive Advertisements. Proceedings of ACM Conference on Advances in Computer Entertainment Technology 2007.
13. DiVerdi, S., Olwal, A. Rakkolainen, I., Höllerer, T. Chapter 14 - An immaterial pseudo-3D display with 3D interaction, Published in: Three-Dimensional Television: Capture, Transmission, and Display (eds. Levent Onural and Haldun M. Ozaktas), 2007.
14. Onural, L., Ozaktas, H., M., Chapter 1 - Three-dimensional television: from science-fiction to reality Published in: Three-Dimensional Television: Capture, Transmission, and Display (eds. Levent Onural and Haldun M. Ozaktas). 2007.

Non-cited literature published under WP12 Tasks 8 and 10:

- Markus Schwab, Peter Noll, Thomas Sikora: "Noise Robust Relative Transfer Function Estimation", EUSIPCO 2006, September 2006
- Reiter, U.: "TANGA Updated – A Modular Framework for Real Time Audio Rendering of Object-Based (MPEG-4) Audio Visual Scenes", Proceedings 51. Internationales Wissenschaftliches Kolloquium (IWK), 2006 September 11-15, Ilmenau, Germany
- Steglich, B.; Reiter, U.: "Sound Source Obstruction in an Interactive 3Dimensional MPEG-4 Environment", in: Proceedings of the 120th AES Convention, Paris, France, 2006 May 20-23, Convention Paper 6705
- Reiter, U.: "Bimodal Perception Phenomena in Interactive Audio Visual Application Systems: an Assessment Framework", ICOB2005, Workshop on Immersive Communication and Broadcast Systems, Berlin/Germany, October 2005
- Reiter, U.: "Audio Rendering System Design for an Object Oriented Audio Visual Human Perception Assessment Tool", DAFx'05, 8th International Conference on Digital Audio Effects, Madrid/Spain, September 2005, ISBN 4-7402-318-1
- Reiter, U., Holzhäuser, S.: "An Input Device for Subjective Assessments of Bimodal Audio Visual Perception", IEEE/ISCE'05, International Symposium on Consumer Electronics, Macau SAR/China, June 2005, ISBN 0-7803-8920-4
- Reiter, U.: "Subjective Assessment of the Optimum Number of Loudspeaker Channels in Audio-Visual Applications Using Large Screens", Proceedings of the AES 28th International Conference, 2006 June 30 to July 2, Pitea, Sweden
- Reiter, U.; Großmann, S.; Strohmeier, D.; Exner, M.: "Observations on Bimodal Audio Visual Subjective Assessments", in: Proceedings of the 120th AES Convention, Paris, France, 2006 May 20-23, Convention Paper 6852
- Reiter, U., Köhler, T.: "Criteria for the Subjective Assessment of Bimodal Perception in Interactive AV Application Systems", IEEE/ISCE'05, International Symposium on Consumer Electronics, Macau SAR/China, June 2005, ISBN 0-7803-8920-4

2.4 Applications (Tasks 11, 12, 13, 14, 15, 16, 17)

As indicated earlier the range of applications of 3D TV and vision are manifold and has a potentially powerful impact on all our lives. Because of the breadth of such applications, we can only cover a few of the more representative ones. The selection here is largely determined by the research interests of the partners involved. For example, we look at multi-target tracking for football applications (Task 11, Sec 2.4.1); air traffic control (Task 12, Sec 2.4.2); the development of MEMS for display development (Task 13, Sec 2.4.3); motion capture with standard video techniques (Task 14, Sec 2.4.4); virtual tours in cultural heritage (Task 15, Sec 2.4.5); simulation of forest fire propagation (Task 16, Sec 2.4.6) and the technologies required for 3D in the mobile domain (Task 17, Sec 2.4.7). However, even then we have only “scratched the surface” of the potential applications which will open up for a user-friendly, comfortable, interactive 3D display.

Task 11: Football-related Applications**Using Multi-target Tracking from Multiple Views for Football-related Applications.**

Participants: ITI-CERTH, TUB, METU

Author: N. Grammalidis

Football is probably the most popular sport activity in the world, especially in Europe and Asia. Not surprisingly, many research efforts are devoted to analyse football games. Needham and Boyle [1] use a multiple object CONDENSATION based approach to track the movements of football players, from video sequences recorded by a single camera on an indoor court. A more recent approach, proposed by Figueroa *et al* [2], performs player tracking using a graph representation of the moving objects in the scene. Another interesting approach for football player tracking, this time using multiple cameras, was presented in [3]. This work was part of the INMOVE project.

Furthermore, with football being such a highly popular sport, there are millions of possible viewers with diverse demands. Some applications developed to satisfy this vast market require football game information to be transmitted through low bit rate channels, i.e. for viewing through a mobile phone device. This information usually includes the position of each player in order for a representation of the game to be constructed. The aim of this task was to develop an automated system based on multiple cameras, which serves such purposes. In other words, it will produce and process information that can be used as an input for a display unit for football games and also is small enough to transmit through a low bit rate channel.

To this goal several image processing algorithms, serving different purposes in the processing chain, were considered, compared and further developed. The first module of the system is the calibration procedure that is applied once to calibrate each video sensor before the system starts to operate. This way it is easy to obtain the exact position of the targets in the real world, so that any point can be converted from image coordinates (measured in pixels from the top left corner of the image) to ground coordinates and vice versa. A calibration technique, based on a 3x3 homographic transformation and correspondences of points and lines, was used [4].

The next and very important module is the background extraction and update module. This is a very critical part of the task as good results in this particular module will result in a good overall performance. Many methods were implemented and tested such as the mixture of Gaussians algorithm [5], the Bayes algorithm [6], the Lluís-Miralles-Bastidas method [7], and non-parametric modelling [8]. The most satisfactory results were achieved by a method proposed by TUB [9]. Instead of the well-known colour spaces (RGB, YCbCr, HSV), the Gaussian colour model is used. It is based on the measurement of object reflectance in colour images and focuses on the description of colour invariants. Various invariant features are obtained from reflectance properties by differentiation.

A target present simultaneously in the field of view of multiple cameras will generally result in multiple observations due to the fact that the blob centres of the same object in two different cameras correspond to close but different 3-D points. In order to

group together all the observations that correspond to the same target, two techniques are proposed, the grid-based technique and the foreground map fusion.

- Grid-based fusion: A grid that separates the overlap area (in world coordinates) in cells is defined. Optimal values for the cell size are determined. Observations belonging to the same cell or to neighbouring cells are grouped together to form a single fused observation.
- Foreground map fusion: In this technique, each autonomous tracking unit initially determines the pixels in each video sensor that are also visible by other video sensors. For these pixels instead of observations, foreground probability maps are generated, i.e. greyscale images describing the probability that each pixel belongs to a foreground object. These maps are fused together (warped to the ground plane and multiplied together), using a technique similar to [10].

The two techniques were evaluated based on test data. The grid-based technique is simpler, faster and requires less bandwidth, while the foreground map fusion technique was seen to robustly resolve occlusions and provide more accurate results.

The tracking unit is based on the Multiple Hypothesis Tracking (MHT) algorithm, which starts tentative tracks on all observations and uses subsequent data to determine which of these newly initiated tracks are valid. Specifically, the tracking unit was based on a fast implementation of the Multiple Hypothesis Tracking algorithm [11]. A 2-D Kalman filter was used to track each target and additional gating computations are performed to discard observation – track pairs. More specifically, a “gate” region is defined around each target at each frame and only observations falling within this region are possible candidates to update the specific track. The accurate modelling of the target motion is very difficult, since a target may stop, move, accelerate, etc. Since only position measurements are available, a simple four-state (position and velocity along each axis) CV (constant velocity) target motion model in which the target acceleration is modelled as white noise provides satisfactory results.

The system was implemented successfully as described in the above sections. We were able to extract football players’ position, tracks and class (shirt colour) information with the use of video input taken from eight cameras placed around the football pitch. The output of the system for every time instant is summarized information for each one of the typically twenty-five observations (twenty-two players, three referees). This information consists of only a few float numbers for every observation to represent the player’s position, track and classification. This way it is possible for the system to work with low bit rate channels and a client-side display unit.

Prototype software has been developed to visualize extracted-football-players in 3D. This software renders artist-made realistic football player models that comprise of nearly 5000 polygons. These models accompanied by 2K texture maps help achieving realistic views. Currently, we succeeded to place virtual players in T-Pose (they are ready to be animated) onto the actual positions of the players. We will try to animate these players considering several parameters such as the velocity vector and player density in the area of interest. Another achievement on this issue is visualization on auto-stereoscopic displays. It is also possible to render these virtual players on a standard auto-stereoscopic notebook, by just creating a special kmz (Google Earth™) file, that contains special features such as time information (required for animation),

3D model placemarks etc. In this way it is quite easy to port this application on auto-stereoscopic platforms. Some of the features of prototype software are: overview map (mini map), point tracks (shows movement of players), referee's-eye view (fixed camera that shows game from the eyes of referee) etc.

To make better use of the system there are a few additional functionalities that need to be implemented. The use of static cameras significantly limits the amount of available test data as the typical cameras used for sport events coverage are moving ones. So a useful future extension will probably require more research on the area of background extraction from moving cameras, an area where a lot of NoE partners have been working on, including TUB. Another issue that needs to be addressed is ball recognition and tracking which would help much more as far as scene understanding is concerned. This could possibly lead to the implementation of a football game analysis tool that can be built according to coaching needs and would be another interesting application concerning this task.

References

1. C.J. Needham, "Tracking and Modelling of Team Game Interactions", Ph.D. Thesis, The University of Leeds, October 2003
2. P. Figueroa, N. Leite, and R.M.L. Barros, "Tracking Soccer Players Using the Graph Representation", In Proc. of the 17th Int. Conf. On Pattern Recognition, 2004.
3. Xu, M., Orwell, J., Lowey, L., Thirde, D, "Architecture and algorithms for tracking football players with multiple cameras", IEE Proceedings - Vision, Image, and Signal Processing Volume 152, Issue 2, p. 232-241, April 2005
4. K. Dimitropoulos, N. Grammalidis, D. Simitopoulos, N. Pavlidou and M. Strintzis, "Aircraft Detection and Tracking using Intelligent Cameras", IEEE International Conference on Image Processing, Genova, Italy, pp. 594-597, September 2005.
5. KaewTraKulPong, P., Bowden, R., 2001. An Improved Adaptive Background Mixture Model for Real-time Tracking with Shadow Detection. In Proc. 2nd European Workshop on Advanced Video Based Surveillance Systems, AVBS01.
6. Liyuan Li, Weimin Huang, Irene Y.H. Gu and Qi Tian, 2003. Foreground Object Detection from Videos Containing Complex Background. In International Multimedia Conference.
7. Lluís, J. Miralles X. and Bastidas, O., 2005. Reliable Real-Time Foreground Detection for Video Surveillance Applications. In VSSN'05.
8. Elgammal, A, Harwood, D. and Davis, L, 2000. Non-parametric Model for Background Subtraction. Computer Vision – ECCV 2000.
9. Karaman, M., Goldmann, L., Sikora, T., 2006. A New Segmentation Approach Using Gaussian Color Model And Temporal Presentation, IS&T/SPIE Electronic Imaging (EI).
10. S. Khan and M. Shah, "A multiview approach to tracking people in crowded scenes using a planar homography constraint", 9th European Conference on Computer Vision, Graz, Austria, 2006.
11. Cox, I.J., Hingorani, S.L., 1996. An Efficient Implementation of Reid's Multiple Hypothesis Tracking Algorithm and its Evaluation for the Purpose of Visual Tracking. IEEE Transactions on pattern analysis and machine intelligence, Vol. 18, pp. 138-150.

Task 12: Air Traffic Control Applications (of 3DTV)

Air Traffic Control Applications

Participants: ITI-CERTH, Bilkent

Author: N. Grammalidis

Introduction

3D visualization can provide significant benefits to the field of air traffic management and control in terms of enhanced understanding and clarity of perception. Within this task, the state of the art in this area was reviewed and an initial assessment of the usability and applicability of 3D technology in the field of ATC (Air Traffic Control) was made, as a basis for a future development of a novel 3D synthetic traffic situation display for airports. Our primary goal was the identification of critical designing issues related to the development of 3D displays for application of air traffic control tasks. The following section stresses the importance of 3D technology in ATC and outlines some basic designing issues.

Research on 3D displays in ATC

The management of flights in a 3D space is usually treated as a 2D problem with altitude displayed as text information. The controllers are, therefore, required to process this data and perceive a three dimensional model in their minds [1]. The actual ATC working position with the 2D interface reaches the limit as the quantity of information increases from the incorporation of automation of tools [2]. Furthermore, the advent of Free Flight will change the current situation dramatically; to this end, how information is presented to controllers or pilots will play a crucial role in the effectiveness of future ATC systems [3].

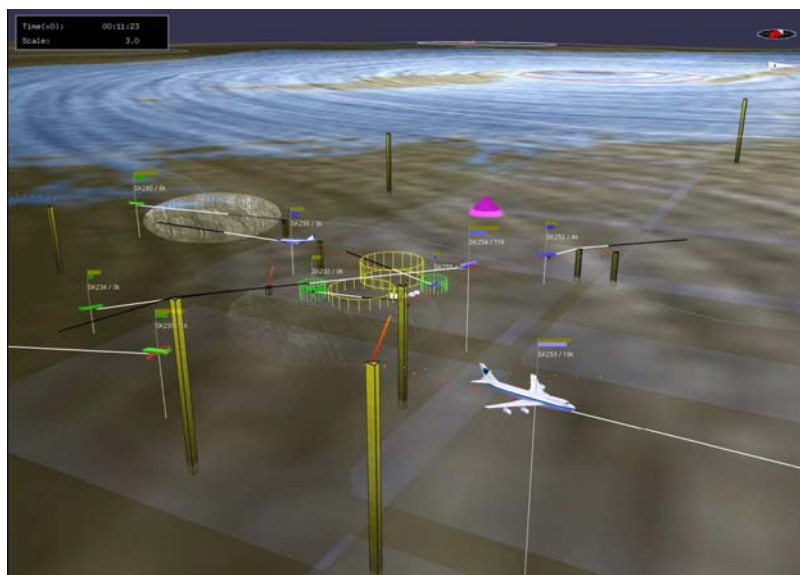

Figure T12-1. Display developed within VISIMOD project [after 1].

3D technology and virtual reality techniques can be applied to air traffic management, providing a traffic situation display, which is accessing the natural ability of human to process 3D data. The replacement of 2D representations with 3D objects and the visualization of spatial information such as terrain, obstacles, buildings etc as well as

the incorporation of weather information will radically change the current working interface. Figure T12-1 shows the application developed within VISIMOD [1] project and provides weather information for the users region of control showing turbulence, icing warnings, air pressure and wind speed information.

However, three important questions are raised about the use of 3D computer graphics within ATC [2]:

- 3D Visualization: how ATC elements should be represented
- 3D Interaction: What are the most appropriate interactions between controllers and the 3D display environment?
- ATC human factors: Could 3D stereoscopic environments be convivial working environment for maintain of controllers, in term of spatial memories, depth perception, etc?

The 3D visualization deals with the graphical representation of objects, e.g aircraft, buildings, trajectories etc. This means that all traffic and decision support information should be represented to controllers in such a manner that the tasks are efficiently assisted [4]. However, a designer of a real-time interactive 3D environment should define the realism level of the application considering the associated computational costs that affects the systems performance. A common practice is the representation of objects with different degrees of details [5]. Dang-Nguyen et al [6] classify ATC objects in two main categories: Physical and Conceptual objects. According to this study, the first category contains objects existing in reality (terrain, aircraft, weather information etc) and thus they require a high degree of realism to be similar to the corresponding real objects. On the other hand conceptual objects do not have a physical reference (e.g. airspace, trajectories, routes or other safety related information). Thus, their representation requires a low degree of realism; nevertheless, it has to be very accurate, since conceptual objects are considered to be essential for controllers' activities.

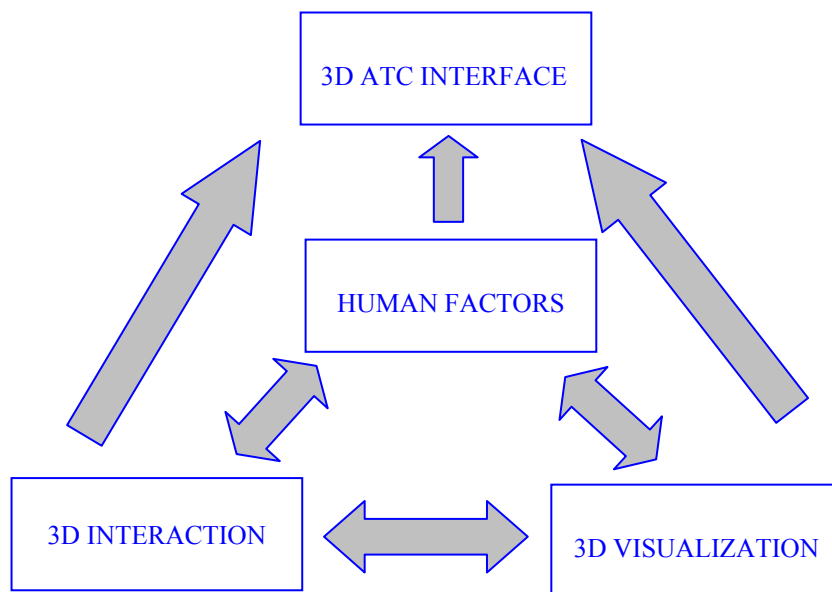

Figure T12-2. The three inter-related components [after 6].

A second important issue is human–computer interaction. A 3D stereoscopic display provides additional interaction capabilities to the air traffic controller, which may require the replacement of traditional mouse and keyboard with some 3D input device e.g. 3D wand, gloves or haptic devices. For example, Lange et al [7] propose a 3D VR system for real time visual representation and manipulation of data in air traffic management and control which uses a wand pointer to navigate in the scene and to select and manipulate flight information within the scene. The wand device can also be used to control rotation of the camera around the view centre in two degrees of freedom and zooming other view as well as to expand the height scale to emphasize the height of the 3D objects such as flight paths and weather information. On the other hand, the ATC-VR, the system developed by Persiani and Liverani [8], uses stereoscopic glasses, a 3D pointing device and the pinch glove to interact with 3D graphical representations. Moreover, Zeltzer and Drucker [9] developed a mission planner using a virtual environment system. In this application, users can interact directly with 3D objects like aircraft, terrain, threats and targets by using voice and gesture recognition. Finally, for Virtual Sky project [6], the interaction equipment available is an Intersense Tracked Wand, with which the users can interact with 3D objects thank to a red ray visualized in the screen display.

In any case, the 3D environment should be designed to support a number of interaction capabilities i.e. controllers may need to navigate within the 3D space and to select and manipulate 3D objects. A basis to start modelling the possible interaction with 3D ATC objects is proposed by Bowman [10], who classified interaction into three basic forms: navigation, selection and manipulation. Of course, the users should be at the centre of the design. Thus the design process, in terms of human factors, has to take into consideration the end-users activities, abilities and needs [6].

Conclusions

Within the project life, the work was mainly focused on the research upon the field of 3D-ATC. Specifically, an initial assessment of the suitability of 3D technology in the area of ATC was performed and some critical designing issues (visualization, interaction, human factors) related to the development of 3D displays were identified. A lot of work still has to be done especially in the area of real time visualization and resolution of conflicts between aircraft in the context of ATC. As air traffic continues to increase in volume and complexity, more conflicts between aircraft can be expected to occur. As a consequence, controllers are exposed to the challenge of being more and more efficient, not only in maintaining the safety of flights but also in the management of flight operations to reduce the complexity of the encounters. Current studies on 3D visualization of conflict focus mainly on the visual representation of conflict, however, a mechanism taking into account both visualization and interaction should be designed to resolve the conflict. Finally, another issue that should be investigated is whether ATC controllers can work in the 3D stereoscopic environment within convenience and satisfaction.

References

1. VISIMOD, 3D Visualization and Interaction for Air Traffic Management.
2. Ha Le-Hong, 3D Visualization in Air Traffic Control, Recherche, Innovation & Vision du Futur 2003, p. 65-70.
3. Ronald Azuma, Mike Daily and Jimmy Krozel, Advanced Human-Computer Interfaces for Air Traffic Management and Simulation, American Institute of Aeronautics and Astronautics, 1999

4. Brown, Mark A. On the Evaluation of 3D Display Technologies for Air Traffic Control, 682, August, Mile End Road, London, 1994
5. ACM SIGGRAPH 2002 Course Notes on Levels of Details, August 2002.
6. Thong Dang-Nguyen, Monica Tavanti, Ha Le-Hong, Vu Duong, Division of Human-Computer Interaction Research report 2004:3.
7. Marcus Lange, Jonas Hjalmarsson, Matthew Cooper and Anders Ynnerman, 3D Visualization and 3D and Voice Interaction in Air Traffic Management, In proceedings of SIGRAD 2003, Umeå, Sweden. ISBN 91-7373-797-6.
8. F. Persiani and A. Liverani, Semi-immersive Synthetic Environment for Cooperative Air Traffic Control, In Proc. of 22nd International Congress of Aeronautical Sciences, Harrogate, UK, 2000.
9. D. Zeltzer and S.M. Drucker, A Virtual Environment System for Mission Planning, In Proc. 1992 IMAGE VI Conference, Phoenix, 1992
10. D.A. Bowman, Interaction Technique for Common Tasks in Immersive Virtual Environments, Georgia Institute of Technology, June 1999.

Task 14: Motion Capture Using Standard Video Cameras**Producing a Motion Capture System Using Standard Video Cameras****Participants:** Yogurt and Koc University**Authors:** C. Turun, H. Ketencioglu, Z. Yugnak, Y Yemez

Optical motion capture is an important research and application area and it is a significant stage for 3DTV. There are two kinds of optical motion capture approaches: Markerless and marker-based. Markers are various shaped and sized tags coated with a retro reflective material to reflect light back. Markerless systems do not use any markers, however they need very stable conditions and special suits. These systems are still being developed and not adequately developed in comparison with marker-based systems [1].

Active and passive marker systems are commonly used for optical motion capture. Active capture systems include active pulsing markers in sync with the cameras' digital shutters [2, 3]. Passive capture systems consist of retro-reflective markers with an illumination source co-located with each camera [4]. Most of these systems use near infrared imaging [4 - 6].

Throughout project period, we have focused on two kinds of imaging approaches. Firstly, we have used color cameras and the color based marker detection approach. Then, we have decided to use higher FPS standard monochrome cameras. Even if our equipment, or marker detection and calibration approaches are changed, most of the remaining stages such as 3D reconstruction and marker tracking are the same as our previous work [7].

In our first work, we have presented an automated multicamera motion capture system for articulated human body model animation [7]. A multicamera acquisition system was built at Koc University in 2006. The multiview video of a moving actor was acquired using 8 synchronized cameras. The proposed motion capture technique is based on 3D tracking of the markers attached to the person's body in the scene without need of an explicit 3D model. We fit a generic 3D skeleton model to detect and track markers. We make use of the multistereo correspondence information from multiple cameras to obtain 3D positions of the markers. This provides us with a set of 3D point locations over time that expresses the alignment of the markers in 3D world. We employ Kalman filtering for smoothing out the observations and predicting the next target locations of the points in that point cloud. The resulting sets of 3D points are then used to animate a personalized skeleton-based 3D human body model. Our initial results were presented at Siggraph 2006: International Conference and Exhibition on Computer Graphics and Interactive Techniques in Boston.

In our previous work and experiments, we had observed that colour based segmentation algorithms are computationally costly and sensitive for noise and illumination irregularity. In our current work, we plan to acquire multiview video of a moving actor using 8 synchronized higher FPS standard monochrome cameras. When we use standard monochrome cameras for near-IR spectrum imaging, markers can be detected in a computationally cheaper manner. Near-IR imaging also provides more useful information and makes marker detection process easier, that's the reason why we decided to use this imaging approach.

Standard cameras have either CMOS or CCD sensors that are sensitive for light spectrum between 380nm to 1000nm wavelength. A light wave between 760nm to 1000nm is part of the near infrared spectrum and this means standard cameras are sensitive for near-IR. Most of the camera users are just interested in visible light spectrum imaging. For this reason, some camera producers put optical filters before camera sensor for cutting IR light [8]. However, some of them do not put any optical filters in front of the camera sensor. So, some of the standard cameras can be used for near-IR imaging by altering the cameras and employing appropriate equipment.

Developing motion capture systems include monochrome cameras, near-IR illumination sources and optical filters that cut visible light and pass near-IR light. We have gotten in touch with some companies for getting more detailed information about prices and specifications of these equipments. We have visited stands of related firms in world of industry fair (WIN' 08) in Istanbul. Finally, we have ordered our system hardware and software. FPS of our new monochrome cameras is higher than color cameras used in our previous work. IR-Led array (850 nm wavelength) projectors will illuminate motion capture zone. Ball shaped and noticeable size retro-reflective markers will be attached on motion capture suit. Appropriate optical lenses will be used with optical filters that cut visible light and just let near-IR light spectrum. By this way, we will avoid undesired effects of the other light sources such as a fluorescent lamp, and the IR light reflecting markers will be the brightest objects in the image. Under this condition, centroid coordinates of markers will be detected easily by simple gray image segmentation approaches.

Camera calibration is an important step for explaining relationship between 3D real world and 2D camera views. Success of this step depends on a robust estimation of lens distortion, intrinsic and extrinsic parameters. Images from each camera view remains undistorted since we take the lens distortion parameters into account. 3D reconstruction is achieved by using projection matrix obtained by camera intrinsic and extrinsic parameters.

Dynamic calibration techniques are used successfully for multicamera acquisition systems in most of the scientific literature and commercial systems [1 - 6, 9 - 11]. Svoboda et al. proposed a calibration method for multiple cameras using one bright point like a laser pointer. The structures of the projected points and their reconstruction by factorization and the re-projection errors, are evaluated in their method [10]. Uematsu et al. proposed calibration software "D-Calib" for multiple cameras that can calibrate all cameras at the same time with an easy operation. In their method, they can also optimize 3D reconstruction errors in addition to 2D re-projection errors which were the only ones taken into account in Svoboda's method [11]. We have already tested most existing algorithms and adapted some of them to our application. We will keep focusing on robust multi-camera self-calibration for successful 3D reconstruction.

3D reconstruction is an estimation of the marker coordinates in the 3D space by using camera calibration matrixes and acquired corresponding 2D coordinates from every camera view. This computation is called triangulation. There are well known triangulation methods such as midpoint method, linear methods, iterative linear methods and polynomial triangulation method [9, 12, 13, 14].

3D reconstruction gives us point cloud in 3D world, these points should be labelled manually by user and Kalman filter will be initialized by these label positions. The 3D positions of markers are tracked over frames by Kalman filtering where the filter states correspond to 3D position and velocity of each marker [7, 15, 16]. The list of 3D points obtained by back-projection of visible 2D points in respective camera image planes constitutes the observations for this filter. This filtering operation has, two purposes:

- smoothing out the measurements for marker locations in the current frame,
- estimating the position of each marker in the next frame and moving the search windows, to those positions by calculating projections of the estimated marker points onto each camera image plane.

Having updated the list of 3D marker positions for the current frame and estimated the locations of search windows for the next frame, we move on processing the next frame starting by looking for the candidate marker positions within new search windows. This algorithm is repeated for the whole video. The list of 3D marker positions over frames is our body model that will be used in the animation process.

Several problems we encountered in our application development process, solutions and prevention measures are listed below:

- The frame rate sets capturing frames per second. If FPS of the camera is inadequate for the speed of target marker, getting an estimation of the marker position will be more difficult. On the other hand, higher FPS cameras are more expensive than low FPS cameras. FPS of the camera should be determined relative to the application type. For instance, estimating positions of the moving markers on a fast moving human actor is only possible by high FPS cameras.
- Markers can be hidden from the cameras (marker occlusion) because of number of cameras, and/or unsuitable positioning of the cameras around the motion capture area. We can cope with this problem by using an adequate number of cameras and by positioning them suitably. For successful 3D reconstruction, every marker should be seen by at least two cameras.

On the marker tracking phase, using fixed size search window is a very simple approach but it causes some problems. When narrow size search window is used, actual marker can be out of this narrow searching area so it can easily cause a lost sight of the actual marker. When a wide sized search window is used, search window can cover more than one marker, so marker tracking algorithm will not be sure about which of them is tracked marker and this confusion is called marker crossover problem. Therefore, search window should be determined dynamically for every marker according to its area. After all these preventions, if there still are marker occlusions and marker crossovers, there is a chance for solving these problems manually by user in the post-processing phase.

Currently motion capture systems under development have a lot of common points with existing commercial optical motion capture systems [4-6], but our system uses standard cameras so it gives us a cost advantage. We will keep focusing on robust multi-camera self-calibration approaches, we will test our core algorithms and construct our software interface in the next period of time.

References

1. Organic Motion, <http://www.organicmotion.com>
2. Phasespace, <http://www.phasespace.com>
3. Standard Deviation, <http://www.sdeviation.com>
4. Vicon, <http://www.vicon.com>
5. Motion Analysis, <http://www.motionanalysis.com>
6. Meta Motion, <http://www.metamotion.com>
7. F. Ofli, Y. Yemez, A. M. Tekalp, C. J. Wetherilt and C. Turun, Multicamera Motion Capture for Articulated Body Model Animation, Koc University-Yogurt Internal Report, Pages:5 , Sep, 2006
8. Cannon, <http://www.usa.canon.com/consumer/controller?act=CanonAdvantageTopicDtlAct&fcategoryid=139&modelid=11154&id=2636>
9. Hartley R., Zisserman A., Multiple view geometry in Computer Vision, Cambridge University Press, New York. 2000
10. Svoboda T., Martinec D., Pajdla T.. A convenient multi-camera self-calibration for virtual environments.PRESENCE: Teleoperators and Virtual Environments, 14(4), 2005.
11. Uematsu Y., Teshima T., Saito H., Honghua C., D-Calib: Calibration Software for Multiple Cameras System.ICIAP 285-290, 2007.
12. Gonzalez, R. C., Woods, R. E., and Eddins, S. L., Digital Image Processing Using MATLAB, Prentice Hall, Upper Saddle River, NJ, 2004.
13. Hartley, R. I, and Sturm, P. Triangulation, Computer Vision and Image Understanding, Vol. 68, No.2, pp.146-157, 1997
14. Beardsley, P. A., Zisserman, A. and Murray, D. W., Navigation using affine structure from motion, in Computer Vision, ECCV'94, LNCS Series 801, pp.85-96, Springer-Verlag, Berlin/New York, 1994
15. R. Kalman, A new approach to linear filtering and prediction problems, Transactions of the American Society of Mechanical Engineers, Journal of Basic Engineering, pp. 35-46, 1960.
16. Trucco E., Verri A., Introductory Techniques for 3-D Computer Vision, Prentice Hall PTR, Upper Saddle River, NJ, 1998

Task 15: Cultural Heritage**A 3D Reconstruction algorithm for a virtual tour system of cultural heritage**

Participants: ITI-CERTH, METU

Author: G Triantafyllidis

Progress to Date

The aim of this task was to develop a Web-based virtual tour system using effective and state-of-the-art 3D reconstruction algorithms, focused at the presentation of archaeological sites. The proposed approach is comprised of powerful techniques such as multiview stereo reconstruction, omnidirectional viewing based on panoramic images and their integration with GIS technologies. In the proposed method, the scene is captured from multiple viewpoints and its 3D geometry is extracted from the acquired images based on stereoscopic techniques. Texture information is then added to this 3D reconstruction of the scene from the available views.

The final representation may be a) point-cloud which can be viewed from different angles or b) modelled surfaces which are covered by images (textures) c) simplified VRML models suitable for conversion and import into Google Earth and finally d) enhanced content for a Web-based interactive virtual tour system allowing 360° viewing, focused at the presentation of archaeological sites.

A 3D scene can be artificially synthesized, e.g. by a 3-D modeller, by performing surface modelling and then manually adding texture information. Current applications are usually Web-based and are composed of elementary and graphical textures which are displayed via a VRML plug-in. The problem with such synthesized 3D models for cultural applications is that the feeling of reality to the end-user is lost and that the procedure to generate them is tedious and requires highly-experienced personnel.

It is argued that utilization of real-image data in texture mapping enhances the feeling of reality for the end-user. The fully automatic multi-view reconstruction of a scene from real-images is not straightforward and, thus, a complete work-path for a reconstruction and presentation of archaeological sites is proposed. In short, this path is:

1. Acquisition of multiple images (preferably of high resolution) or video-recording and subsequent selection of key frames.
2. Computation of internal camera calibration parameters.
3. Estimation of lens distortion and image rectification.
4. Extrinsic calibration of the acquired images, based on robust feature extraction, tracking and camera motion estimation techniques,
5. Multi-view stereo reconstruction of the scene using the acquired images and intrinsic and extrinsic calibration parameters.
6. Conversion of the reconstruction output to textured VRML format, which includes triangulation of points into a mesh, combination of textures from different images
7. Display of the reconstructed portion of the archeological site, as a VRML-like (Collada) file on the Google Earth™ system. To this end, and due to Google Earth™ limitations, simplified VRML models have to be used.

The method in [1] is utilized for the automated 3D modelling of the archaeological scenes. This technique stereoscopically processes images of the scene that are

acquired from multiple viewpoints to produce its 3D reconstruction. As is the case for most multiview stereo reconstruction techniques, the accuracy of the final results depends on the quality of both intrinsic and extrinsic camera calibration. To efficiently tackle the problem of fully-automatic calibration, the proposed approach is based on state-of-the-art algorithms for this problem [2-8], as well as custom modifications of these techniques that target the accuracy-improvement of our calibration results (e.g. robust feature point detection and matching using SIFT 9 and bundle adjustment¹⁰).

The reconstructed VRML models are integrated with GIS technologies within a web-based virtual tour system, after first converting them to the XML-based Collada 3D file format, and then referencing to them in Keyhole Markup Language (KML), a format supported by the GoogleEarth™ GIS platform. Excavation site plans are used as detailed raster overlays, draped over terrain at the exact locations on the earth. When the reconstructed archaeological site is placed on top of the site plan, users view the reconstruction together with the site plan.

Additional information (e.g. site-related audio or text) can be presented to users via hot-spots. We added a hyperlink to the application described above, which directs users to a panoramic image based virtual-tour. Using a map of the archaeological site increases the comprehension of the tour and enhances the user's sense of orientation. With such tools, more information is communicated to the virtual tour users in an ergonomic fashion.

A larger degree of “immersiveness” can be experienced by viewing the reconstructed 3D models on autostereoscopic displays, which can be achieved by using a special plug-in, TriDef™ Visualizer for GoogleEarth™, to render real-time 3D scenes. Using a map of the archaeological site increases the comprehension of the tour and enhances the user's sense of orientation 11. By enhancing our system with these tools, more information can be effectively communicated to the virtual tour users in an ergonomic and educational fashion.

Achievements, milestones and breakthroughs

The Task has achieved most of its main goals, although many extensions are possible in the future. A list of the achieved milestones are listed below

Results/Milestones
Completion of the camera estimation software from multiple images using SIFT features (working prototype)
Completion of the 3-D reconstruction software to produce VRML files. (working prototype)
Conversion of data (multiple images) from the “Dion” archaeological site to VRML (http://www.ii.metu.edu.tr/~3daegean/3d_reconstruction/) and GE
Conversion of data (multiple images) from “Knossos” archaeological site to VRML (see above link)
Integration of 3D reconstructions within a GE (samples are included in above link)

However, additional work needs to be done on:

- Improvements and optimizations of the modules of the processing chain
- Integration and full automation of the software to create full-resolution VRML files and simplified models suitable for GoogleEarth™
- There exist limitations on the allowed number of vertices and triangles that can be supported by GoogleEarth™ exist – even if a VRML model is below these limits,

a complex VRML file may significantly slow down GoogleEarth™. Therefore, tools and algorithms to generate simpler VRML models need to be investigated.

- Further Integration of results to create Web-based virtual tours supporting 360° viewing and hyperlinks. This requires further Web development, although expertise exists³

Technological and scientific roadblocks to overcome

Binocular stereo movies (2+1/2D), including those focused on cultural heritage applications, have had more public acceptance than completely freeview movies. Several 2+1/2D movies have already been released for the general audience, in the cinemas. Probably what is most preventing the same technology entering consumers' homes (as a TV or home cinema) is the high cost of a projection system as well as the special configuration that is required for the projection room (e.g. blank wall, empty space). In terms of producing (2+1/2D), a higher production and direction cost is observed. In addition, watching the movie requires polarized glasses is an unfavorable interface and many people would prefer glass-free viewing. The solution of autostereoscopic displays has limitations, regarding the viewing angle and distance range as well as used from multiple viewers. Both of the polarized and autostereoscopic displays can produce fatigue effects to the viewers when watching for a long duration. Finally, holographic displays do not exhibit any of the above problems, but they are still extremely expensive and are not mature enough.

Completely free viewpoint movies are not currently produced. The main problem appears to be content acquisition, which is still imprecise and prone to uncontrolled illumination and outdoor conditions. In addition, a very large number of cameras is typically required to completely cover a scene. Pilot 3D videos are for the moment produced only in highly controlled studio environments after a fine calibration of the camera setup.

For presentation and 3D modelling of outdoor cultural heritage, the proposed approach as a whole constitutes an economic and practical alternative to the 3D scanner technology. With respect to content creation for 3-D viewing applications, the problems that have been identified are the following:

Accurate feature selection and matching (especially when repetitive textures) is probably the most important task to be fulfilled to achieve accurate 3-D reconstruction. To this end, SIFT technique has shown to be extremely robust, especially when it is combined for robust algorithms for 3-D camera motion estimation and 3-D reconstruction. However, the necessary amount of overlap between two views is always a significant issue: if it is too small, errors may occur; if it is too large, a large number of images may be required to reconstruct the desired area.

Specific SIFT parameters still need to be manually adjusted, so that a desired number of points is obtained for the 3-D camera estimation task. Tools to automate this task may be considered in the future.

In some cases, some post-processing, i.e. manual correction of specific 3-D reconstruction errors may still be required for some difficult scenes.

³ e.g. http://www.ii.metu.edu.tr/~3daegean/cappadocia_tour/virtualtour.htm

Google Earth is yet unable to visualize very complex VRML scenes (more than 30.000 triangles). Also, as the number of triangles increases interactivity capabilities are hindered.

What has been done by people out of the NOE

Significant technical improvements have been published in all areas of 3DTV such as capturing 3D scenery, data transmission, 3D signal processing and 3D displays, which in turn span a wide range of topics from imaging to signal processing, telecommunications to optics and physics. Such topics can be reviewed at the proceedings of conferences such as IEEE 3DTV-CON and IEEE 3DPVT. In the market, prime movie distribution companies have released theatric 2+1/2 movies (e.g. "U2").

What still needs to be done and who is likely to do it

Stereoscopic displays are now available at the market both for cinemas and home application. It can therefore be predicted that companies are to continue production on this issue probably focusing at lowering the cost of such devices. The same holds for stereoscopic content creation. Currently, theatrical movies are being produced by major companies using the iMax technology. It is thus predicted that this trend will continue and be expanded by these companies.

Regarding content creation for 3D freeview point movies, the technology is not yet commonly available and it is therefore predicted that research scientists along with collaboration with companies are to produce the future technologies. Only after such efforts, consumers are going to be able to use products which can display 3D freeview video.

References

1. Zabulis, X., Patterson, A. Daniilidis, K. 2003. "Digitizing Archaeological Excavations from Multiple Views", 3DIM2003.
2. Sturm, P., Triggs, B., 1996, "A Factorization Based Algorithm for Multi-Image Projective Structure and Motion", 4th European Conference on Computer Vision (ECCV 96).
3. P.H.S. Torr and A. Zisserman. MLESAC: A New Robust Estimator with Application to Estimating Image Geometry. In Journal of Computer Vision and Image Understanding, pages 138-156, 78(1), 2000.
4. P. A. Beardsley, A. Zisserman, D. W. Murray, Sequential Updating of Projective and Affine Structure from Motion, Int. J. Computer Vision (23), 1997.
5. Pollefeys, M., Koch, R., Vergauwen, M., Van Gool, L., 1999, "Hand-held acquisition of 3D models with a video camera", 3DIM1999.
6. Tola, E., 2005, "Multi-view 3D Reconstruction of a Scene Containing Independently Moving Objects", M.Sc. Thesis, Middle East Technical University, Ankara, Turkey.
7. Martinec, D., Pajdla, T., 2002, "Structure from many perspective images with occlusions", European Conference on Computer Vision (ECCV 02) and LNCS 2351.
8. Svoboda, T., Martinec, D., Pajdla, T., 2005, "A Convenient Multi-Camera Self-Calibration for Virtual Environments", PRESENCE: Teleoperators and Virtual Environments, 14(4), August 2005.
9. David G. Lowe, "Distinctive image features from scale-invariant keypoints," International Journal of Computer Vision, 60, 2 (2004), pp. 91-110.
10. M.I.A. Lourakis and A.A. Argyros, "The Design and Implementation of a Generic Sparse Bundle Adjustment Software Package Based on the Levenberg-Marquardt Algorithm", Tech Report No.340, Institute of Computer Science - FORTH, Heraklion, Crete, Greece, August 2004.
11. Bastanlar, Y., "User Behaviour in Web-based Interactive Virtual Tours", 29th International Conference on Information Technology Interfaces (ITI 2007), 25-28 June, Dubrovnik, Croatia.

Task 16: Wildfire Simulation on 3D-GIS Environment**Wildfire Simulation on 3D-GIS Environment**

Participants: ITI-CERTH, METU, Bilkent

Author: E Cetin

In the last few years with the increase in the global warming, the world climate is changing. Two of the several main reasons in the global warming are the hole in the ozone layer and the destruction of the vegetation. These two issues invoke each other, thus consisting a vicious cycle. Due to the hole in the ozone layer the climates are changing and the due to the climate changes the vegetation is being destroyed. One of the main causes of destruction in recent years is wildfires. The increase in the seasonal temperatures also increased the number of self-ignited wildfires in mostly forest areas. Urged by the dry winds, and dry vegetation, some of these fires became disasters. Early detection is a very important issue for efficient fire intervention. It is much easier to cope with wildfires when they are local. Shorter the time between the ignition and the detection of fire, it is easier to extinguish it. While planning the deployment of fire fighters and equipment, estimation of the propagation of fire is very advantageous.

Parallel to the developments in computer sciences and electronics, the current trend is the development of automatic systems to cope with the problems mentioned above. Traditionally, governments hire people to monitor the potential fire regions. Governments construct observation posts at relatively high areas around the fire regions and place human observers at these posts. However by human observation alone, it is impossible to monitor the vast forest areas continuously. Hence, there is a significant need for automatic fire detection systems. The level of maturity of the existing solutions is relatively low. Therefore fire detection and propagation prediction is an open research issue. Several European countries are conducting research on these issues.

In 3DTV project we are currently working on 3D Fire Simulation software, which can simulate the spread of a wildfire and visualize it on a 3D display in 3D. The spread calculations are done using a library called 'fireLib' [1]. "fireLib" was developed using "Behave" algorithm, (Andrews [2]) by Bevins, USDA Forest Service Rocky Mountain Research Station. We developed new procedures for the dynamic calculation of the landscape parameters (slope, aspect, elevation) and fire propagation. We developed libraries for the integration of fireLib with Shuttle Radar Topography Mission (SRTM) data. In this way, the calculation of the fire propagation on a dynamically changing landscape is achieved.

The next phase is the visualization of the fire propagation. This visualisation is important since (i) it enables early intervention of the fire and (ii) it helps to fire department to recruit the fire equipment easily. The fire propagation software in the literature yield a 2D view (mostly a top view) of the fire-site which may not provide a clear view of the situation to the persons responsible for the deployment of fire-fighting forces. Our aim is to visualize this raw propagation data on a more user-friendly 3D-GIS environment. For this purpose Google Earth™ is used in the proposed system. The main reasons of choosing Google Earth™ are because it is public available and widely used by experts and non-experts. Also it allows the

creation of impressive 3-D animations of the fire propagation, in addition to the static view.

Moreover, due to its layered design, Google Earth™ provides the developer (and the user) enhanced flexibility to visualize various types of additional information on the map. For instance, the timeline of the propagation can be colour-coded and displayed. Positions of the deployed equipment, observation posts, fire-fighting units etc. can also be visualized on the map. An example view of the colour-coded propagation visualization can be seen in Figure T16-1. The timeline of the fire propagation is colour coded on the map. The red coloured cells represent the areas, which will burn first, and the cells with colour blue or its tones represent the cells that will ignite later. On the top of this colour-coding layer, another independent layer of time stamps is placed. These time stamps show the estimated ignition time of each cell.

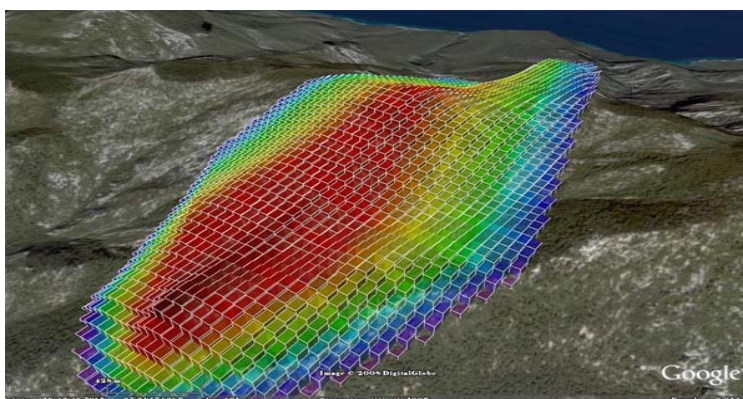

Figure T16-1: Ignition times using colour coding

Red and its tones show the areas that will burn first, while blue and its tones show the areas which will burn later.

Another layer is the flame length layer. Especially in the animations of fire propagation, the flame length layer gives visually interesting results. With the dynamic calculations described in Section Figure T16-2, the flame length changes in time so more realistic animations can be created.

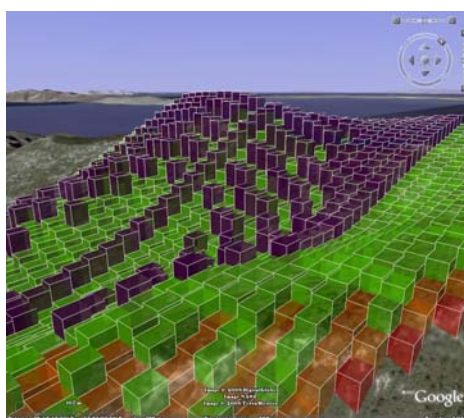

Figure T16-2: Flame length information is shown in frames of propagation animation.

[This type of animation can be visualised in 3D on *Sharp Actius™* autostereoscopic notebook]

Another possible layer can be the roads, rivers, and fountains etc., which also play a crucial role to finalize the fire-fighting plan. All these layers are independent from each other; therefore the user can visualize all of them at once or chose the one he/she wants. Also all these layers can be visualized in 3D on an autostereoscopic display. In this way, the fire-fighters can plan their movements against the wildfire more easily.

Google EarthTM gives the availability of tilting and panning the view, thus allowing user interaction and enhancing the 3D feeling of the visualization (Figure T16-1). By this way a more realistic visualization of the topographical information of the terrain is achieved. The user can view the fire area from any angle and a more efficient fire deployment can be achieved.

Another advantage of Google EarthTM is that it can be visualized in 3D using different types of 3D displays (Tridef, [3]). We have demonstrated several test fires on autostereoscopic displays, such as Sharp Actius AL3DUTM. As a result, very realistic 3D visualization is obtained (Figure T16-3). The 3D visualization can be both static (Figure T16-1) or dynamic (animations, as in Figure T16-4). Besides the terrain information, all the other layers can also be visualised in 3D. Together with the tilting and panning, the 3D view makes the user feel, as if he/she is at the fire area.



Figure T16-3: Flame length information is shown in frames of propagation animation.

[This type of animation can be visualised in 3D on *Sharp ActiusTM* autostereoscopic laptop]

For using realistic flame lengths in these visualizations, new software modules are developed. The time specific flame length maps will then be imported, visualized and/or used to create animations showing the spread of a fire within the Google EarthTM platform. For this reason, KML/KMZ files are generated. The use of KML/KMZ file formats will also allow us to visualize results on several other popular GIS platforms as well. Integrating all the mentioned components above and the video based smoke detection system mentioned in (Toreyin [4]), a complete wildfire detection and simulation system with a 3D visualization will be created.

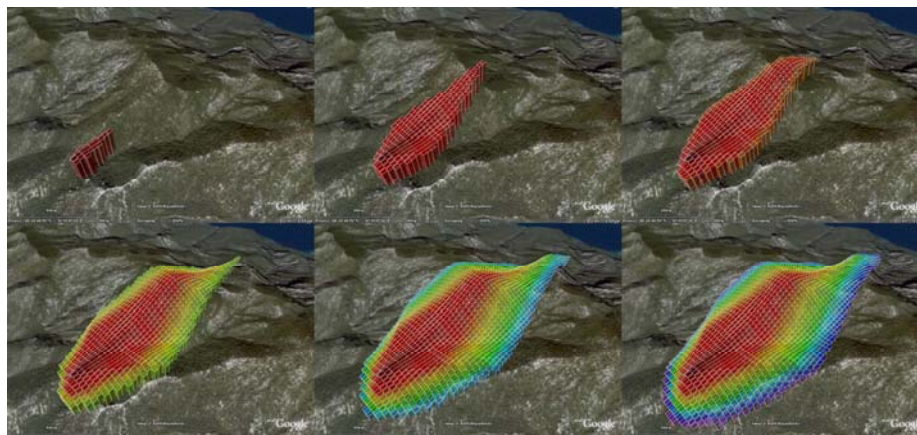

Figure T16-4: Animation of fire propagation is composed of several frames showing the propagation at different times.

Recently, we have also designed and we are currently testing a Web interface, based on PHP, that allows a user to specify/adjust all necessary parameters related to the fire modelling procedure (e.g. number and dimension of cells, geographic coordinates of the ignition point, etc.), as well as the desired type of visualization (currently ignition time and dynamic animation of flame length are supported, but more may be defined in the future). By pressing a specific button, the fire simulation can be executed on the server and the resulting KML file is provided to the user, which can be visualized on Google Earth™ or stored for future reference. Although this interface is still in a testing phase, we plan to further extend it in the future (e.g. making it more user friendly, supporting more types of visualisations, adding fuel maps, obtaining useful information, e.g. water areas or elevation, directly from Google Earth™, etc).

Currently the main roadblock in this application is the calculation of the fuel models. Since the fireLib library was developed by USDA, the models within the library are suitable for the forests of USA. The fuel models of the regions on which the software will be used, must be investigated. Bilkent and METU will investigate on the fuel models of Turkey and ITI-CERTH will do the same investigation for the forests of Greece.

Another library that we want to work on is the real-time calculation of the wind speed. After the landscape, one of the main factors, which affect the propagation speed, is the direction and speed of the wind. We want to develop software, which can estimate the local wind direction and speed from video.

References

1. fireLib, 2008. fireLib software implementation and documentation, <http://www.fire.org/index.php?option=content&task=category§ionid=2&id=11\&Itemid=29> (accessed 20 April 2008).
2. Andrews, P. L., 1986. Behave: Fire Behavior Prediction and Fuel Modelling System - BURN Subsystem Part 1, USDA Forest Service General Technical Report INT-194, 1986.
3. TriDef, 2008. TriDef-Supported 3-D Displays, <http://www.tridef.com/display/profile/all.html> (accessed 20 April 2008).
4. Toreyin, B. U., Dedeoglu, Y., Gudukbay, U., Cetin, A. E., 2006. Computer Vision Based System for Real-Time Fire and Flame Detection, Pattern Recognition Letters, Vol.27 pp. 49-58.

Other Non-cited Relevant References

- Kose, K., Grammalidis, N., Yilmaz, E., Cetin, A. E., 3D Wildfire Simulation System, XXI Congress The International Society for Photogrammetry and Remote Sensing (ISPRS), 2008.
- Toreyin, B. U., Dedeoglu, Y., Cetin, A. E., 2005. Wavelet Based Real-Time Smoke Detection in Video, Proc. 13th European Signal Processing Conference - EUSIPCO 2005.
- Firementor, 2008. Firementor project, Greek National Project, <http://www.firementor.gr/english.htm> (accessed 20 April 2008).
- Keramitsoglou, I., Kiranoudis, C.T., Sarimvels H. et al., 2004. A multidisciplinary decision support system for forest fire crisis management", Environmental Management, Vol.33, No.2, pp.212 – 225.
- Rohermel, R. C., 1972. A Mathematical Model for Predicting Fire Spread in Wildland Fires, USDA Forest Service General Technical Report INT-115, Ogden, UT.
- Andrews, P. L., 1986. Behave: Fire Behavior Prediction and Fuel Modeling System - BURN Subsystem Part 1, USDA Forest Service General Technical Report INT-194, 1986.
- Rothermel, R. C., 1983. How to Predict the Spread and Intensity of Forest and Range Fires. USDA Forest Service General Technical Report INT-143, Ogden, UT.
- Dimitrakopoulos, A. P., G. Xanthopoulos, and V. Mateeva, 1999. Statistical Classification of Mediterranean Fuel Types in Greece, Proc. of the International Symposium on Forest Fires: Needs and Innovations, pp. 125-131.
- Xanthopoulos, G., Manasi, M., 2002. A Practical Methodology for the Development of Shrub Fuel Models for Fire Behavior Prediction", Forest Fire Research and Wildland Fire Safety: Proc. of IV International Conference on Forest Fire Research, Wildland Fire Safety Summit, Luso, Coimbra, Portugal, pp. 18-23.
- Cadell, W. 2002. Report on the generation and analysis of DEMs for spatial modelling, <http://www.macauley.ac.uk/LADSS/documents/DEMs-for-spatial-modelling.pdf> , (accessed 20 April 2008).
- Horn B.K.P., 1981, Hill shading and the reflectance map, Proceedings of the I.E.E.E. 69, 14.

Task 17: Applications in the mobile domain**Investigation of technologies and applications of 3DTV to the mobile domain**

Participants: Bilkent, FhG-HHI, TUT, UNIABDN

Authors: T. Capin, K. Pulli (Nokia Research), T. Akenine-Möller (Lund University)

Summary

The purpose of this task is to study mobile 3D graphics solutions, 3D user interfaces, and applications. The study considers the limitations, potential problems, and some of the requirements of mobile phones to support 3DTV technologies. The main theme was to investigate state-of-the-art in mobile end-user applications, such as user interfaces, visualization, games, and augmented reality.

Introduction

The mobile phone is one of the most omnipresent devices in the world: before the end of 2008 3.3 billion people, half of the world population, will be using a mobile phone. Over the past 10 years, the phone has grown from being just a phone to being a full multimedia unit, where you can play games, shoot photos, listen to music, watch television or video, send messages, do video conferencing, and still use it as a normal phone.

A key component has been the dramatic improvement in display technologies. Less than ten years ago, there were one-bit displays with very low resolution (e.g. 48 x 84 pixels), and today, 24-bit (16.8 million colours) displays with VGA resolution (640 x 480 pixels) and higher are common. What is interesting and inspiring with this trend is that it makes computer graphics a core part of phones today. With more than one billion mobile phones being sold each year, and the numbers still growing, it is obvious that this device is the most widespread unit with capabilities to render images. As such, it promises to deliver 3DTV for the masses in the future.

The mobile context is, of course, also vastly different from the desktop or laptop PC context. A mobile phone is always with you. A mobile phone is always connected to the network and can find its location through a GPS radio or by base station triangulation, and provides access to location-based services and navigation, and many such applications require a graphics-intensive user interface. A large fraction of modern mobile phones also include a 3D-capable Graphical Processing Unit (GPU) and camera, which allows many possibilities for better user interaction with the device, as well as augmented reality (AR) applications that combine 3D digital (rendered graphics models) with the real world (images on a camera viewfinder).

Mobile Device Limitations

There are some inherent differences and limitations on hand-held devices when compared to the desktop. Below we list the most important of these limitations:

- Power supply limitations. The fundamental problem of mobile devices is that they are battery-operated devices. Whereas many other aspects of computing have followed Moore's law, battery technology develops at a much slower rate. The display is one of the biggest consumers of power, and graphics applications keep the display, often with back-light constantly on. Innovation is required at the hardware level for lower power consumption, as well as diligence in writing power-aware mobile applications.

- Computational power limitations. Mobile device CPUs are limited in computing power. There are several reasons for this, the most important one being the power limitations described above. A related limiting factor is the internal bandwidth for memory accesses, which increases at a slower rate than the raw computing power, and also consumes a lot of power. Other reasons include cost: mass market consumer devices should be cheap, which limits the silicon budget. For example, only the most recent high-end phones have begun to support floating-point units. Finally, the devices are physically small, and even if more power were available, that power turns into heat, which can damage the circuits unless the thermal aspects are taken into account early in the design process. Having dedicated graphics hardware helps the devices get by with lower clock-rate CPUs.
- Physical display size limitations. Although the pixel pitch ratio is increasing at a stable rate, the requirements to keep the devices hand-held and pocketable means that the physical size of the devices has an upper bound. Whereas the largest displays may have a diameter of up to five inches, many devices have much smaller displays than that.
- Input modality are limitations. Mobile devices currently support key-based interfaces through joypad/direction keys and numerical keyboard. On devices with larger form-factors, additional keys provide a better user experience for complex tasks such as navigating through large amount of content, since keys can be dedicated to specific tasks such as page-up/down and choosing zoom level. Smart phones cannot easily make use of such keys due to limited physical space. Stylus-based interaction with touch-sensitive screens has emerged as an alternative, but most solutions require two-handed interaction which has been shown to cause additional attentional overhead in users.

There is an order of magnitude difference between high-end and low-end devices in graphics processing and computational capacity. A particular technique may run efficiently in one type of device, but would be inefficient on other devices. This requires solutions which can scale down to smaller devices such as low-end mobile phones, and up to larger devices, even desktop displays.

3D Graphics Hardware and APIs

A foundation for mobile 3D applications has been laid by standard mobile graphics APIs. For three-dimensional graphics, there is OpenGL ES, which is a low-level API based on the popular OpenGL, and M3G (JSR 184), which is designed on top of OpenGL ES, and provides support for scene graphs, animation, and file formats for mobile Java. Pulli *et al* [1] provide a survey of existing mobile 3D APIs.

A given task, such as three-dimensional rendering, can always be done more efficiently on special-purpose hardware than on a general-purpose CPU. It is possible to write a rendering engine fully in software executing on a CPU, and that approach provides maximum flexibility. In fact, the majority of the mobile 3D engines currently shipping are still software implementations. However, with dedicated graphics hardware, it is possible to provide the double benefit of both faster execution and lower power consumption. Dedicated graphics processing units (GPUs) have already started to appear on high-end smart phones. Some of the GPUs are available on a separate chip, but often the GPU is integrated on the same chip as the CPU to obtain lower manufacturing cost.

The key to good graphics performance and low power consumption is to reduce the internal traffic between the processing elements and the memory. Therefore, mobile 3D graphics solutions pay extra attention on how to compress and even completely avoid that traffic. This is made even more important with the trend that computation power increases at a faster rate than memory bandwidth. For example, Owens [2] uses the reliable International Technology Roadmap for Semiconductors (ITRS), and reports that the processing capability growth is about 71%, while DRAM bandwidth only grows by 25%. This is an enormous difference, and suggests that great care should be taken when designing GPU architecture.

Compression is a well-known technique to save storage space, but it can also be used to reduce the amount of bandwidth used to send the data over a network or over a memory bus. For GPUs, there are two major targets for compression and decompression (codec), textures and buffers. Textures are most often considered asymmetric, as read-only images which are glued onto geometrical primitives such as triangles. A new codec, called ETC (Ericsson Texture Compression) [3], has been adopted for OpenGL ES. This technique was designed so that the size of a hardware decompressor is very small, and currently, this algorithm is not used in any desktop graphics APIs. Buffers are different in that they are more symmetric in terms of compression and decompression, since both processes must be carried out in hardware in real time. Buffers have been used for applications where the texture needs to change in run time.

Similar to buffer compression/decompression (previous subsection), the goal of tiling architectures is to reduce the memory traffic related to frame buffer accesses. However, a completely different approach is used here. Tiling the frame buffer so that a small tile is stored on the graphics chip allows many possibilities for optimization and culling. Commercially, both Imagination Technologies and ARM provide a mobile 3D accelerator using a tiling architecture. The core insight in them is that a large chunk of the memory accesses are to the various buffers, such as color, depth, and stencil. Ideally, we would like to have the memory for the entire frame buffer on-chip, which would make such memory accesses extremely inexpensive. However, that is usually not practical for the whole frame buffer, but storing a small tile of, say, 16 x 16 pixels of the frame buffer on chip is feasible.

There are also methods to reduce power usage at a much lower level, i.e., at the hardware level. Several researchers have started to propose low-power GPUs with conventional power management strategies. Mochocki et al. [4] present power consumption analysis of mobile 3D graphics pipeline stages. The authors analyze the effects of various factors such as resolution, frame rate, level of detail, lighting, and texture maps on power consumption. Based on this analysis, they use dynamic voltage and frequency Scaling (DVFS) schemes for different stages of the mobile 3D graphics pipeline. With a prediction strategy for workload of different pipeline stages, the DVFS solution could decrease power consumption of graphics rendering by 40%.

Rendering on 3D (Autostereoscopic) Displays

Already with stereo rendering, rendering generally costs twice as much in terms of computations and bandwidth. However, for a larger angle of usage, some displays use even more views, which requires still more processing. Specialized hardware can help to handle efficient rendering with autostereoscopic displays by utilizing that fact that

the images for the left and right eyes are very similar. With a brute-force implementation, the scene is first rendered to the left eye, and then to the right eye. In general, however, it is a better strategy to render a single triangle to both views before proceeding with the next triangle. Kalaiah and Capin [5] use this rendering order to reduce the number of vertex shader computations. By splitting the vertex shader into parts that are view-independent (and hence only computed once) and view-dependent, vertex shader computations can be greatly reduced. In the per-pixel processing stage that follows, a simple sorting procedure in a generalized texture space greatly improves the texture cache hit ratio [6], keeping the texture bandwidth very close to that of monoscopic rendering. In addition, Hasselgren and Akenine-Möller [6] introduce approximate rendering in the multi-view pipeline, so that fragment colors in all neighboring views can be approximated from a central view when possible. When approximative rendering is acceptable, this technique can save a lot of per-pixel shader instruction executions. For stereo rendering, about 95% of the computations and bandwidth is avoided for the left view (the right view must be rendered as usual).

Visualisation and 3D User Interfaces

The problem of how to present large data and complex user interface components more effectively on small displays is an important topic for visualization on handheld devices. When the data complexity exceeds what the mobile displays can show at a time, users are either required to browse through the data sequentially by manually navigating through the large data, or to use more effective visualization techniques. Various researchers have addressed the problem of rendering and visualization of 3D data, such as medical data or city models. Zoomable User Interfaces also emerged as an area that uses visualization techniques. 3D User Interfaces are potentially an important visualization tool on mobile devices, especially those with autostereoscopic displays. 3D will benefit more on mobiles than on desktops, because of the limited physical screen size.

Creating 3D interfaces that approach the richness of 3D reality has long been a research target of several other research groups, particularly for desktop environments. Shneiderman and Plaisant [7] analyzed the features of effective 3D interfaces, primarily for desktop and new-to-eye display domains, and have proposed a number of guidelines. These include better use of occlusion, shadows, and perspective; minimizing the number of steps in navigation; and improving text readability with better rendering and contrast with the background, among others.

Graphics hardware support for OpenGL ES 2.0 in a mobile phone opens up new possibilities for user interfaces due to the programmable nature of that API. As 3D UI rendering solutions developed for desktop computers do not scale down well to mobile devices, different set of widgets need to be developed. Programmable vertex and pixel shaders have been used to render depth-of-field effect and motion blur, as well as to animate “wobbly” windows using vertex skinning (e.g. see SocialRiver technology).

User input to 3D UIs is another problem that needs to be solved. Mobile devices are currently limited in the mode of interaction they provide to users. Interaction is supported by key-modal interfaces through joypad and direction keys and the numerical keyboard. Direct Manipulation Interfaces provide a more intuitive

interaction style than current menu-based systems [7]. The user is provided with a means of manipulating individual objects, each with a direct display representation.

Stylus-based solutions, although accurate in selection of objects in a small screen, require two-handed interaction and have been shown to cause additional attentional overhead in users. To overcome this problem, one-handed thumb-based interaction solutions have been introduced recently. Apple's iPhone is the most prominent example of such devices, which, with a multi-touch capacitive touch screen, allows users to interact with applications and type using their thumb.

A number of solutions have been proposed for using the camera as the input device, where incoming camera video is used to estimate phone motion and to interact with the user's physical environment [8]. With camera-based interaction, the user moves the pointer or changes the view by moving the phone, instead of interacting with the screen or keypad. Correctly interpreting the observed motion of the objects or the global motion of the camera from video requires accurate tracking. Various tracking algorithms have been proposed—markerless and marker-based techniques. Markerless tracking solutions analyze the video and detect important features, such as edges, corners, or corner-like features; or use motion-flow techniques for the global motion of the camera. Marker-based solutions use a visual tagging system based on printed 2D markers that are placed in the environment and identified by mobile cameras. Better 3D interaction using these techniques needs to be investigated in the future.

Augmented Reality Interaction

Augmented Reality (AR) means looking at the real world around you and augmenting the experience, usually by adding images of virtual objects or annotations such as names of buildings over the scene. AR can be contrasted with Virtual Reality where everything is rendered with computer graphics, and telepresence where reality somewhere else is conveyed by transmitting video and audio. Whereas many mobile graphics applications are similar to desktop graphics applications, only with more constraints and less performance, AR can provide a fundamentally different and better user experience on a mobile system than is possible on desktop.

The biggest remaining challenges in mobile AR relate to object recognition and real-time 3D tracking for unprepared markerless environments. A secondary problem is seamlessly blending the graphics objects with the real scene with correct occlusions and shading; this requires modeling the environment and the current illumination levels in real time, on the device.

Challenges for the Future

The many limitations of the mobile device, and its particular features (such as the fact that it is always with you, always connected) make the topic of mobile 3D applications vastly different from desktop PC. The field is very young, and there are many challenges that lie ahead.

It is quite clear that specialized graphics hardware is needed for power-efficient 3D graphics processing, and further research remains to be done. The core of the problem is that battery capacity generally improves at a much slower rate than both CPU and GPU capabilities. One could (and should) of course ask when the processing power of

a mobile device is sufficient. We believe that the situation is similar to that of desktop PC, i.e., the available processing power is always spent, no matter how much is available. For example, writing a text message can always be improved by on-the-fly spell-checking, anti-aliased font rendering, grammar checking, even speech-to-text conversion. Naturally, for user interfaces and games, the processing power needs are much bigger. So, a better battery will not solve our problems completely, and processing power and extra energy from the battery will be quickly spent. Therefore, we believe that the best way forward is to continue to work on all fronts, which includes more efficient high-level graphics hardware algorithms, intelligent low-level power management, clever software techniques for rendering and transmission, among other things. This also includes handling large, complex models and data sets. For both software and hardware techniques and algorithms, it would be convenient to have a “knob” which the user can “turn” in order to trade off image quality and operation time. Approximate rendering for graphics hardware is a field which has not been investigated thoroughly, and we expect that many new innovations will emerge.

Autostereoscopic displays can provide a major breakthrough on mobiles before it does so on desktops. Interestingly, several such displays can already switch between displaying a standard two-dimensional image, and conveying a three-dimensional autostereoscopic experience. Graphics APIs could easily add some support for these displays. For 3D TV and video there are still open issues in standardization organizations, but these are making fast progress. In practice the biggest practical obstacle for autostereoscopic displays has been creation of content that takes full benefit of such display.

User interfaces is an area where lots of innovation will happen at every level. The low-level APIs, such as OpenVG and OpenGL ES are there, but really using 3D so that it truly benefits the user experience is still an open and active research issue. Multi-modal interfaces that integrate voice, gesture (through sensors such as accelerometers and cameras), stylus/finger, and keyboard input with interactive graphics and sound rendering, and take human perceptual and cognitive capabilities into account, will create easier and more fun-to-use interaction experience with the device. Games are traditionally good at creating interfaces that are naturally easy to use, where instruction books are not required, hopefully these aspects of UI become more widespread in mobile UIs in general.

The camera of the mobile device makes augmented reality (AR) an avenue worth exploring more, since most users have a camera in the device. As such, there is a bigger possibility to create AR applications with very widespread use. However, the “killer application” still needs to be found.

Work Done

A survey paper of Mobile 3D graphics, 3D user interfaces, and augmented reality solutions, as summarized in this section, has been accepted for publication at IEEE Computer Graphics and Applications, July/August 2008 issue. It presents a comprehensive survey of recent activities and predictions for future.

A number of FP7 projects, which aim to develop future Mobile 3DTV related technologies, have been accepted and have started in 2008:

The 3DPHONE project aims to develop technologies and core applications enabling a new level of mobile 3D experience, by developing an all-3D imaging mobile phone. The aim of the project is to realise all fundamental functions of the phone i.e. media display, user interface (UI), and personal information management (PIM) applications in 3D but usable without any glasses. The project aims to build a 3D phone prototype at the end.

The Mobile 3DTV project has the goal to develop and demonstrate the viability of the new technology of mobile 3DTV. It will comprise the following features: suitable stereo-video content-creation techniques; efficient, scalable and flexible stereo-video encoders with error resilience and error-concealment capabilities, tailored for robust transmission over DVB-H; and also the corresponding stereo-video decoders and players working on a portable terminal device equipped with a stereoscopic display.

References

1. PULLI, K., AARNIO, T., MIETTINEN, V., ROIMELA, K., AND VAARALA, J. 2007. "Mobile 3D Graphics with OpenGL ES and M3G". Morgan Kaufman.
2. OWENS, J. D. 2005. Streaming Architectures and Technology Trends. In GPU Gems 2. Addison-Wesley, 457–470.
3. STRÖM, J., AND AKENINE M. 2005. "High-Quality, Low-Complexity Texture Compression for Mobile Phones". In Graphics Hardware, 63–70.
4. MOCHOCKI, B. C., LAHIRI, K., CADAMBI, S., AND HU, X. S. 2006. Signature-based workload estimation for mobile 3d graphics. In DAC '06: Proceedings of the 43rd annual conference on Design automation, ACM, New York, NY, USA, 592–597.
5. KALAI AH, A., AND CAPIN, T. 2007. Unified Rendering Pipeline for Autostereoscopic Displays. In Proceedings of the 3DTV Conference.
6. HASSELGREN, J., AND AKENINE-MOLLER", T. 2006. An Efficient Multi-View Rasterization Architecture. In Eurographics Symposium on Rendering, 61–72.
7. SHNEIDERMAN, B., AND PLAISANT, C. 2004. "Designing the User Interface", 4th ed. Addison Wesley.
8. CAPIN, T., AND HARO, A. 2008. Handbook of Research on User Interface Design and Evaluation for Mobile Technology. Information Science Reference, ch. Mobile Camera Based User Interaction, 541–555.

2.5 Market Survey

Clearly, there are many problems facing the 3D-research community before we will see 3D vision techniques as commonplace. Some of these problems include the aforementioned human factors, but also the performance of the technology and the applications affect this acceptance. A market survey of user requirements and wishes is therefore vital if we are to progress in the right direction. Such a survey has been prepared and is outlined here (Task 18).

Task 18: Consumer Market Survey**Preparation of a consumer market survey on 3DTV technology**

Participant: Momentum

Author: Cigdem Eroglu Erdem, Tanju Erdem, Mehmet Ozkan

Note: This Task is additional to those appearing in the DoW.

Three-dimensional television has enormous consumer market potential. Whether this potential is realisable or whether the technology will join the rank of failed promises depends on many factors. The quality of the product, its applications, and how it is marketed will play important roles in the outcome. Therefore, it is very important to understand the economics of such consumer markets, as well as how consumers perceive such a technology.

Starting from the issues discussed in the report “Three-Dimensional Television: Consumer, Social and Gender Issues” prepared by Prof. Haldun Özaktaş, we designed a consumer market survey, the aim of which is to understand the economics of consumer markets, as well as how consumers perceive the 3DTV technology.

The survey was presented at the TC5 meeting during the third General Research Meeting in Frankfurt. It will be distributed for evaluation to people from different backgrounds and ages. Finally, the gathered survey data will be analysed and a final report will be written.

The questionnaire is shown in [35]

References

1. Questionnaire:
http://www.surveymonkey.com/s.aspx?sm=69b_2f988ZzVSO_2bojWU4eyug_3d_3d

3 Papers and Summaries.

As is now traditional for our network reports, we present a summary of the latest publications by members of WP12 since TR2, relating specifically to holographic and autostereo displays, associated human factors and applications. We also include a personal (Editor's) assessment of their contribution and impact on the general landscape of 3DTV. The abstracts for these papers are presented here and the full texts can be found in the Appendices. A look at the list of recent publications has shown that the number of papers published since the last technical report has decreased. This is due, partly to the shorter timeframe covered by this report, and partly to the publication of longer, more detailed and more comprehensive papers. However, the quality and potential impact of the publications on the wider stage remains high. Many of these papers appeared in top-rank journals, while more appeared at conferences around the world underlying the increasing impact of our network on the world of 3DTV. Of 34 publications included (and in press) 25 are in conference proceedings (including 3DTV-CON, Istanbul), 8 are in peer-reviewed journals and one is a patent application. Increasing numbers of papers (19) are joint contributions between two or more NoE partners (often across workpackages) and often with collaborators outwith the network.

3.1 General

1. Benzie, P., Watson, J., Surman, J., Rakkolainen, I., Hopf, K., Urey, H., Sainov, V., von Kopylow, C., *3DTV Displays: Techniques and Technologies*. **Trans CSVT** **17**, 11, 1647-1658, (2007)¹

The display is the last component in a chain of activity from image acquisition, compression, coding transmission and reproduction of 3D images through to the display itself. However, the display is the most visible aspect of 3DTV and is probably the one by which the general public will judge its success. The concept of the 3D display has a long and varied history stretching back to stereo-photographs made in the late 19th century through 3D movies in the 1950's, holography in the 1960's and 70's and the 3D computer graphics and virtual reality of today. Many technologies manifest themselves today as the basis of 3D displays including stereoscopic, volumetric, head-mounted and, of course, holography. In this paper some of the important technologies in today's 3D displays are outlined, together with a review of the state-of-the-art and how these displays may develop in the future.

Editors Comment: This paper is based on the state-of-the-art review prepared by members of TC5 in the early stages of the network. This updated and revised version represents what is probably the most complete review of 3DTV displays to date.

3.2 Holography

2. Lukas Ahrenberg, Philip Benzie, Marcus Magnor and John Watson, *Computer generated holograms from three dimensional meshes using an analytic light transport model* **App Opt** **47**, 1567 – 1574 (2008)²

This paper describes a novel CGH method to render solid polygonal 3D models. Similar to the above mentioned methods it is based on propagation using the angular

spectrum of plane waves. In contrast however, no per polygon FFT is necessary. We have derived an analytic formula for the frequency distribution of a diffusely shaded triangle. The rendering is performed directly in frequency space. When transforming the angular spectrum we can then operate on this function instead of a sampled representation of the surface. It is thus possible to compute the frequency distribution of a general triangle in the hologram plane analytically, thus eliminating the need of an FFT per polygon. In addition, the wavefront is only sampled at the plane of the hologram, mimicking the physical process, where the hologram quality is only dependent on the resolution of the recording medium. Only one Fourier transform for the whole hologram, transforming the final angular spectra to a wave field is needed. This allows for a potentially very fast method.

Editors Comment: This paper epitomises the philosophy of the 3DTV network: a coming together of researchers from opposite ends of the 3D vision spectrum. In this case, researches with experience in holography collaborated with those from the computer vision sphere to produce work that extended the capabilities of CGH's.

3. Murat Sayinta, Serhan O. Isikman, Hakan Urey, *Scanning LED Array based Volumetric Display* **IEEE 3DTV-CON 2008**, Istanbul (May 2008)³

A novel quasi-holographic display concept is developed using Light Emitting Diode (LED) arrays integrated on a standard PCB platform. The display system is capable of providing smooth motion parallax and solving the accommodation-vergence rivalry. Each scanner module contains 1D LED array mounted on a polymer scanner with a lens for imaging the LEDs onto a special diffuser screen. The display concept is proven successfully by using 3 of these modules and showing the viewer different points at different depth levels. The main advantage is that the display is easily scalable for different vertical and horizontal resolutions by integrating PCB scanner modules in vertical and horizontal direction respectively in a way similar building LEGO blocks.

Editors comment: A novel implementation of a quasi-holographic display based upon an LED array to give a moderately wide-angle view. It helps to move somewhat towards smoothing out motion parallax and helping to reduce some of the problems with accommodation.

4. Veysel Yücesoy, Doruk Tunaoglu, Metodi Kovachev, Rossitza Ilieva, Levent Onural, *Design and Implementation of a DMD based volumetric 3D Display*, **IEEE 3DTV-CON 2008**, Istanbul (May 2008)⁴

A real image swept-volume volumetric display is developed. A piston type moving screen is used to obtain the desired volume. A commercially available DMD device is used to project 2D slices of a 3D frame. There is a varying magnification effect during the projection because of the optical design of the system; raw 3D video frames are processed by a software to generate the appropriate 2D slices by also correcting the magnification. Synchronization between the hardware and the software is achieved via a microcontroller. The overall system is capable of printing 12 by 3D frames per second where a 3D frame consists of 90 by 2D slices with a resolution varying from 512 x 512 to 450 x 450 (approx. 20 Mvoxels per one 3D frame). Although some

flickering effect is observed due to rather low 3D frame rate, results are visually satisfactory.

Editors Comment: Work based on volumetric display and use of a DMD to project image slices. Good resolution is claimed, but best image view is directly towards the screen. This is another example of how the network has prompted participants to consider ideas outwith their normal area of activity and promote novel ideas.

5. Fahri Yaras, Metodi Kovachev, Rossitza Ilieva, Mostafa Agour, Levent Onural, *Holographic reconstruction using phase-only spatial light modulators*, **IEEE 3DTV-CON 2008**, Istanbul (May 2008)⁵

Phase-only spatial light modulators are used for reconstructions from inline phase holograms that are calculated by Gerchberg-Saxton iterative algorithm. Although iterative procedures are slow in computing holograms, we obtained sufficient results with a rather low number of iterations. We have shown that reconstruction of 2D objects whose sizes are larger than SLM size is possible. Not only single plane 2D objects but also several objects in different depths are reconstructed using phase holograms by superposing their complex diffraction patterns. Results of both numerical and optical reconstructions from phase holograms are satisfactory.

Editors Comment: A useful paper showing some of the developments in application of SLM technology. In particular, the authors concentrate on evaluating phase-only SLM's for replay of holograms. This paper represents collaboration between Bilkent and BIAS and is the product exchange visits between the two institutions.

6. Elena Stoykova, Ventseslav Sainov, Georgi Minchev *3D Scene capture by Multi-wavelength pattern projection at divergent illumination of a sinusoidal phase grating*, **IEEE 3DTV-CON 2008** Istanbul (May 2008)⁶

The paper focuses on the performance of a phase-shifting profilometric system with a sinusoidal phase grating as a projection element under simultaneous multi-wavelength projection of four phase-shifted patterns at divergent illumination and simultaneous multi-camera registration. The quality of the projected fringes is evaluated by calculation of the Fresnel diffraction integral for a spherical wave illumination at paraxial approximation as well as by measurement of the contrast and the spectral content of the fringes as a function of the distance from the grating. The good quality of fringes is proved by simulation of the four-wavelength profilometric measurement. An accurate restoration of a 3D test object (dome) from experimental data is presented.

Editors Comment: This paper is aimed more at recording than displays. However, the techniques employed could eventually have an impact on applications of 3DTV. As such, it is an important paper.

7. T. Yovcheva, I. Naydenova, I. Vlaeva, R. Todorov, V. Toal, S. Sainov, *Optical properties of charged polymer with nano-sized zeolite inclusions*, **Jnl Optoelectronics and advanced materials** (In press, 2008)⁷

The optical characteristics of photopolymer films doped with nanoparticles are studied. The investigated systems consist of a soft polymer matrix containing porous zeolite nanoparticles with concentrations varied in the range from 0% wt. to 7% wt. 40µm thick layers are obtained by casting the photopolymer nanocomposite solution on glass substrates. The corona charging influence on the transmission spectra and on the surface and the effective refractive index of the dry layers is investigated.

8. T. Yovcheva, K. Beev, TZ. Petrova, V. Dragnostinova, G. Mekishev, and S. Sainov, *Electric charge influence on holographic recording in photopolymers*, **Journal of Optoelectronics and Advanced Materials** (In press 2008)⁸

Azo-polymers are very attractive recording media for holographic investigations. Low cost, good optical characteristics alongside with good light sensitivity and ease of production are their unique properties. In the present work, we report the results of the electric charge influence on the diffraction efficiency of thick holographic gratings. Some of the samples have been preliminary charged by two different methods – the corona discharge method, and the thermal polarization method and the results compared.

Editors comment: These two papers (7 and 8) discuss work related to photopolymer materials, their parameters and how they are useful in holography. They fit within our theme of investigation of novel and advanced recording/display materials for holography. Both papers were presented at the Condensed matter Conference, Turkey (2008).

3.3 Autostereo

The following batch of papers all relate to the work on autostereo performed within the consortium.

9. Edward Buckley, Alex Corbett, Phil Surman, Ian Sexton, *Multi-Viewer Autostereoscopic Display with Dynamically-addressable Holographic Backlight*, **SID2008** (2008)⁹

An autostereoscopic display system, which allows multiple viewers simultaneously by use of head-tracking, was previously demonstrated for TV applications in the ATTEST project. However, the requirement for a dynamically addressable, movable backlight presented several problems for the illumination source. In this paper, the authors demonstrate how the use of a novel laser-based holographic projection system can be used to address these problems.

Editors comment: The authors are clearly tackling many of the outstanding problems related to 3D displays. In this paper, they adopt laser-based projection methods to overcome problems related to restricted viewing, loss of resolution and limited depth-of-field by adopting novel display geometries.

10. Ian Sexton, Edward Buckley, *ATTEST to MUTED – Problems, Answers, and the Evolution of a Multiple Mobile Viewer Autostereoscopic Display* **IMID 2008** (2008)¹⁰

The ATTEST (Advanced Three dimensional Television System Technologies) project (IST-2001-34396) ran from 2002 to 2004. Led by Philips, Eindhoven, there were seven other participants in the project, which had the ambitious objective of producing an entire 3D-TV broadcast chain, from capture/synthesis, through coding and transmission, and ultimately, display. There were two facets to the display development: a single user system, which was the responsibility of FhG HHI and a multi user system produced by DMU. A common philosophy was shared in both displays; it was deemed essential for a TV application that the system should be autostereoscopic and viewers should enjoy freedom of movement. In addition, the DMU display would cater for several viewers simultaneously. Both approaches use headtracking to provide viewer mobility

Editors Comment: The ATTEST project culminated in the production of the HHI 'Free2C' display and a 'proof of principle' prototype of a multi viewer display was demonstrated by DMU(2). The fundamental limitations of the current displays are being addressed the EC funded MUTED project. This work clearly demonstrates the success of 3DTV in helping to bring together multi-disciplinary teams from across Europe to advance autostereo displays.

11. Phil Surman, Ian Sexton, Klaus Hopf, Wing Kai Lee, Edward Buckley, Graham Jones, Richard Bates, *European Research into Head Tracked Autostereoscopic displays*, **IEEE 3DTV-CON 2008** Istanbul (May 2008)¹¹

Stereoscopic displays that do not require the wearing of special glasses (autostereoscopic), enable a large degree of freedom of viewer movement and show the minimum amount of information have been developed within several European Union-funded projects. In the ATTEST and MUTED projects a stereo image pair is produced on a single liquid crystal display (LCD) by simultaneously displaying left and right images on alternate rows or columns of pixels. Novel steering optics is used to direct regions, referred to as exit pupils, to the appropriate viewers' eyes. The positions of these are controlled by the output of a head position tracker. In the HELIUM3D project an autostereoscopic image is produced with the use of a light engine and illumination is provided by an RGB laser. Exit pupil locations are determined by a head tracker controlling a spatial light modulator (SLM).

Editors Comment: This work spins out from the ATTEST and MUTED projects and again demonstrates the power of several laboratories from across Europe (including industry) to tackle the common problems faced by autostereo display technology.

12. Phil Surman, Ian Sexton, Klaus Hopf, Wing Kai Lee, Edward Buckley, Graham Jones, Richard Bates, *Laser-based Multi-user 3D Display*, **ASID'07**, Singapore (Aug 2007)¹²

13. Phil Surman, Ian Sexton, Klaus Hopf, Wing Kai Lee, Edward Buckley, Graham Jones, Richard Bates, *Laser-based Multi-user 3D Display*, **Jnl SID**, 16/6 (2008)¹³

Editors comment: The two papers above (12 and 13) are similar. One (#13) is an extended version of the other and was adapted for journal publication. They both extend the groups previous work in suitable sources for auto-stereo display by considering laser illumination. This relates to their HELIUM3D project and is an important step forward.

14. Klaus Hopf, Paul Chojecki, Frank Neumann, *Novel User Interaction Technologies in 3D Display Systems*, **IEEE 3DTV-CON 2008** Istanbul (May 2008)¹⁴

This paper describes recent advances in the R&D work achieved at Fraunhofer-HHI that are believed to provide key technologies for the development of future human-machine interfaces. The paper focus on the area of vision based inter-action technologies that will be one essential component in future three-dimensional display systems.

Editors comment: In this paper the authors address the interactivity issues of autostereo technology and how they may be tackled. Hand tracking, eye tracking and gesture interaction are discussed along with proposals for a display incorporating all such techniques. Again, this is an extremely valuable contribution to the autostereo field.

3.4 Applications

The range of applications described here is both wide and deep (literally!) and stretches from applications in visualisation of cultural heritage to deep-sea imaging of plankton. While some of these applications may be a long way from the 3D, wide-angle, interactive display we imagine, they are an important step in the right direction.

3.4.1 Cultural Heritage

15. Xenophon Zabulis, Nikos Grammalidis, Yalin Bastanlar, Erdal Yilmaz, Yasemin Yardimci Cetin, *3D Scene Reconstruction Based on Robust Camera Motion Estimation and Space Sweeping for a Cultural Heritage Virtual Tour System* **IEEE 3DTV-CON 2008** Istanbul (May 2008)¹⁵

This study focused on the realistic representation of archaeological sites and its presentation in a Web-based virtual tour system. In the proposed approach, the scene is captured from multiple viewpoints utilizing off-the-shelf equipment and its 3D structure is extracted from the acquired images based on stereoscopic techniques. Colour information is added to the generated 3D model of the scene and the result is converted to a common 3D scene modelling format. The 3D models are integrated with GIS technologies in which the excavation site plans as detailed raster overlays, and made reachable via Internet.

Editors comment: The work presented discusses the application areas of 3DTV technologies in cultural heritage. Realistic models are created for archaeological sites, which can be viewed from any point of view. Integration with GIS technologies is important for interactive applications, where the users are able to search and navigate for different locations. This work is a good example of the network participants looking to the future. It also brings together the expertise of three different institutions across two countries.

16. Yalin Bastanlar, Erdal Yilmaz, Yasemin Yardimci Cetin, Nikos Grammalidis, Xenophon Zabulis, Georgios Triantafyllidis, *3D Reconstruction for a Cultural Heritage Virtual Tour System*, **IEEE 3DTV-CON 2008** Istanbul (May 2008)¹⁶

17. Yalin Bastanlar, Erdal Yilmaz, Yasemin Yardimci Cetin, Nikos Grammalidis, Xenophon Zabulis, Georgios Triantafyllidis, *3D Reconstruction for a Cultural Heritage Virtual Tour System*, **ISPRS 2008**¹⁷

The aim of these studies (16 and 17) was to build a Web-based virtual tour system, focused at the presentation of archaeological sites. The proposed approach is comprised of powerful techniques such as multiview stereo reconstruction, omnidirectional viewing based on panoramic images, as well as, integration of the above with GIS technologies. In the proposed method, the scene is captured from multiple viewpoints and its 3D geometry is extracted from the acquired images based on stereoscopic techniques. Colour information is added to this 3D reconstruction of the scene and the result is provided to a 3D visualization tool for rendering. his study focused on the realistic representation of archaeological sites and its presentation in a Web-based virtual tour system. In the proposed approach, the scene is captured from multiple viewpoints utilizing off-the-shelf equipment and its 3D structure is extracted from the acquired images based on stereoscopic techniques. Color information is added to the generated 3D model of the scene and the result is converted to a common 3D scene modelling format. The 3D models and interactive virtual tour tools such as 360° viewing are integrated with GIS technologies in which the excavation site plans as detailed raster overlays. Realistic models are created for the archaeological sites which can be viewed from any point of view. Since models are image-based, viewers expectations for the real appearance of the objects is met considerably. Integration with GIS technologies is important for interactive applications, where the users are able to search and navigate for different locations.

Editors comment: The two papers (16, 17) again address how 3DTV technologies can tackle the requirements of a virtual tour display of cultural heritage sites. Cultural heritage applications are likely to be some of the most suitable uses of 3D.

3.4.2 Fire Propagation Simulation and Modelling

18. Kivanc Kose, Nikolaos Grammalidis, Erdal Yilmaz, and Enis Cetin *3D Forest Fire Propagation Simulation IEEE 3DTV-CON 2008* Istanbul (May 2008)¹⁸
19. Kivanc Kose, Erdal Yilmaz, Nikolaos Grammalidis, Bahadir Aktug, A. Enis Cetin, Ilhami Aydin, Boyutlu Orman, Yangini Sistemi, *3D Forest-Fire Spread Simulation System IU 2008*¹⁹

In this work a fire propagation simulator, which can visualize the propagation of a forest fire in 3D, is presented. The key parts of the simulator are the propagation calculator and the 3D visualization. The simulator starts with the determination of the coordinates of the fire ignition point. Using parameters like, the fuel characteristic of the fire area, slope, aspect, wind speed, the propagation of the fire is calculated as a timeline. Fuel models defined by U.S. Department of Agriculture Forest Service are used in the simulations. Digital Terrain Models of the forest area is used to obtain the slope, height and aspect information. A new method is developed to efficiently use this huge amount of DTM data.

After the calculation of the fire propagation a new method of visualizing this data in 3D is developed. Sharp Actius™ notebook computer is used while visualizing the simulation results. By the help of the Trideft™ visualizer plug-in, a 3D visualization of the fire propagation in real time is achieved. Besides a static visualization, also an

animation of the fire propagation in 3D can be viewed. The animation visualizes the spread of the fire in time. By this application a new application area for 3D visualization is proposed. It is aimed to show that the research of 3DTV group is not only restricted to “television” but also any other area, which is open to 3D visualization.

20. Kivanc Kose, Enis Cetin, Erdal Yilmaz, Nikos Grammalidis *3D Wildfire Simulation System*, **ISPRS 2008**²⁰

Climate change due to global warming is threatening the vegetation of the world. The lack of rains and the rise in temperatures are the main causes of self-ignited wildland fires. Currently many countries are using human centred wildland fire detection systems. However, the average alarm times for these systems are in the range of minutes or in some cases hours. Therefore, the importance of the automatic fire warning systems is increasing. Detecting the wildland fire by video-based techniques is the first step of a multiple phase task. After detecting the fire, the main focus is on estimating the propagation direction and speed of the fire. Only a few of the available visualisation systems give the user the ability to visualise fire propagation on a Geographic Information System (GIS) environment. Here in this paper we are presenting a fire propagation modeling system, which utilizes Google Earth™ as the 3D-GIS visualization environment. Among the algorithms given at we chose “fireLib” to be used.

Editors comment: The above three papers(18, 19, 20) all describe the modelling and simulation of forest fire development and propagation. This is clearly an important application for any aspect 3D technology and the work here describes in important advances in the visualisation of such fires.

3.4.3 2D-Immaterial Displays

21. Olwal, A., DiVerdi, S., Rakkolainen, I., Höllerer, T., Consigalo, *Multi-user, Face-to-face Interaction on an Immaterial Display with Adaptive Audio*, **Second International Conference on INtelligent TEchnologies for interactive enterTAINment INTETAIN 2008**, Mexico, (January 2008)²¹

In this paper, we describe and discuss interaction techniques and interfaces enabled by immaterial displays. Dual-sided projection allows casual face-to-face interaction between users, with computer-generated imagery in-between them. The immaterial display imposes minimal restrictions to the movements or communication of the users. As an example of these novel possibilities, we provide a detailed description of our Consigalo gaming system, which creates an enhanced gaming experience featuring sporadic and unencumbered interaction. We describe the technology used in the system, the innovative aspects compared to previous large screen gaming systems, the gameplay and our lessons learned from designing and implementing the interactions, visuals and the auditory feedback.

22. Rakkolainen, I., *Measurements and Experiments of Immaterial Virtual Reality Display*, **IEEE 3DTV-CON 2008** Istanbul, (May 2008)²².

The immaterial projection screen is an emerging display technology that enables to create high-quality projected images in mid-air. It can also be extended to become a mid-air pseudo-3D or virtual reality display, but free viewing and oblique projection angles impose severe problems for the technology to be used as a virtual reality screen. In this paper we present some light scattering measurements and experiments of the technology to map out some limitations of it in order to develop a better pseudo-3D FogScreen.

23. Rakkolainen, I., *Recent Developments in the Immaterial Projection Screen technology (poster)*, **Society for Information Displays (SID 2008)**. Los Angeles, (May 2008)²³

The immaterial projection screen is an emerging display technology that enables high-quality projected images in mid-air. It is becoming more wide-spread and can be extended to a pseudo-3D display. In this paper, we present an overview of the technical and commercial state-of-the-art of the technology.

Editors comment: The above three papers all relate to the development of the FogScreen “Immaterial” projection system. Although fundamentally 2D it does give the user the appearance of 3D. It is beginning to gain a foothold in the market place for large-scale projection displays and is to be commended for this.

24. Rakkolainen, I., *Display screen based on particles carried in a fluid stream*, **Patent Application PCT/FI2007/050364** (June 2007)²⁴

Editors comment: No abstract is available for this for “commercial-in-confidence” reasons. However, the application for a patent is an indicator of the novelty of the system and the company’s belief that they have a technology that will have a major impact of the display market.

25. Jumisko-Pyykkö, S. Hellsten, S. Weitzel, M., Rakkolainen, I., *Children’s Game Experiences in Different Settings*, **IEEE 3DTV-CON 2008**, Istanbul (May 2008)²⁵.

Games provide enjoyment and positive experiences for players. The goal of this paper is to examine children’s game experiences between physical gaming on the immaterial FogScreen and a mouse-based PC gaming. The systematic game evaluation experiment was conducted with 20 children. Game experiences were measured quantitatively using a children-friendly flow questionnaire and a qualitative interview for gathering playing impressions. The results showed that FogScreen provided novel gaming experience, was funnier and children enjoyed its naturalness and possibilities to move compared to PC set-up. However, the interaction with the FogScreen set-up was harder, providing lower level of playability and controllability than PC set-up.

Editors comment: The FogScreen “Immaterial Display” is gaining a lot of favour by many large companies for its pseudo-3D qualities. This paper looks at the wider aspects of its application to children’s games and how human factors influence the users’ enjoyment. As the the use of 3D displays grow in acceptance the influence of human factors will have an increasing impact on public acceptance.

3.4.4 Holography in Life Sciences

The following set of papers relate to work carried out at one of our partners on the design and development of a digital underwater holographic camera and its application to the imaging, identification and measurement of marine organisms such as plankton. Only a few laboratories world-wide are involved in this type of activity and at the time of writing the Aberdeen camera is the deepest deployed down to greater than 450 m in the North Sea.

26. H Sun, DC Hendry, MA Player, J Watson, *In situ Underwater Holographic Camera for Studies of Plankton*, **Jnl Oceanic Eng**, **32**, 373-383 (2007)²⁶

In this paper, the authors describe the design, manufacture and field testing of an underwater electronic holographic camera (eHoloCam) that has been developed for in situ studies of the distribution and dynamics of plankton and other marine organisms and particles. The eHoloCam uses an Nd-YAG pulsed laser to freeze-frame fast moving particles and a complementary metal-oxide-semiconductor (CMOS) sensor for high-resolution image capture. Digital holograms and holographic videos are recorded at rates from 5 to 25 Hz over a period of several hours. Data is stored locally on an embedded computer. The eHoloCam is capable of recording all organisms and particles located in a water volume of 36.8 cm³ in a single hologram frame. The recorded holographic videos are reconstructed numerically at a desired image plane. To record electronic holographic videos of marine organisms, the eHoloCam was towed at speeds up to 4 knots (about 2 m s⁻¹) in the North Sea.

27. H Sun P Benzie, N Burns, D Hendry, M Player, J Watson, *Underwater digital holography for studies of marine plankton*, **Phil Trans Roy Soc** **366**, 1789-1806 (2008)²⁷.

This paper reports on the use of a subsea digital holographic camera (eHoloCam) for the analysis and identification of marine organisms and other subsea particles. By comparison with other imaging techniques, an e-hologram has several advantages such as three-dimensional spatial reconstruction, non-intrusive and non-destructive interrogation of the recording sampling volume and the ability to record holographic videos. The basis of much work in optics lies in Maxwell's electromagnetic theory and holography is no exception: we report here on two of the numerical reconstruction algorithms we have used to reconstruct holograms obtained using eHoloCam and how their starting point lies in Maxwell's equations. Derivation of the angular spectrum algorithm for plane waves is provided as an exact method for the in-line numerical reconstruction of digital holograms. The Fresnel numerical reconstruction algorithm is derived from the angular spectrum method. In-line holograms are numerically processed before and after reconstruction to remove periodic noise from captured images and to increase image contrast. The ability of the Fresnel integration reconstruction algorithm to extend the reconstructed volume beyond the recording sensor dimensions is also shown with a 50% extension of the reconstruction area.

28. H Sun, D Hendry, N Burns, J Watson *Ocean plankton imaging using Proc OCEANS07 Aberdeen, 070417-001*, (2008)²⁸.

In this paper, the authors describe an electronic holographic camera for in situ underwater studies of the distribution and dynamics of plankton and other marine organisms and particles. A summary is given of the performance in four in situ deployments in North Sea and Faeroe Channels at water depths ranging from about 10 m to 450 m. eHoloCam is capable of capturing opaque and transparent organisms in the size range from about 50 μm up to 10 mm. The recorded holographic videos are reconstructed numerically using one of our reconstruction algorithms at various planes through the light path. The overall system resolution for the recorded images is 8 μm and 36 μm at a distance of 100 mm and 470 mm, respectively. Also shown are various images of marine organisms recorded on these 4 cruises, and preliminary data on size distributions of *Calanus* are also presented and discussed.

Editors comment: The above three papers (26, 27, 28) all relate to design, development and field-testing of a digital holographic camera for analysis of plankton in the ocean. Design details of the camera are discussed in the first papers concentrates on the, whereas the second emphasises the algorithms used in recording and replay. The third concentrates on the 4 field cruises undertaken. The camera represents the state-of-the-art in subsea holography and its application to the imaging and monitoring of marine organisms.

29. N Burns, M Player, J Watson, *Data extraction from underwater holograms of marine organisms* **Proc OCEANS07 Aberdeen, 070130-004**, (2008)²⁹.

A digital holographic camera was developed for in situ underwater studies of the distribution and dynamics of plankton and other marine organisms and particles. Digital holograms are recorded at rates from 5 Hz to 25 Hz as holographic videos over a period of several hours. Data is stored in the camera on an embedded computer. eHoloCam is capable of recording all organisms and particles located in a water volume of 36.8 cm^3 in a single hologram frame. The recorded holographic videos are recreated numerically, using a variety of reconstruction algorithms, at a desired image plane. The vast amounts of data stored in holographic videos presents a major challenge for the automation of image extraction, identification of species and hence analysis of the holograms. In this paper, the authors describe some of the algorithms used to optimise hologram reconstruction and, subsequently, image quality. The problems of automating the data extraction, the implementation of auto-focus methods and the definition of regions of interest in the eholovideo reconstruction procedures are outlined. In covering each of these and their amalgamation into a single algorithm, the authors describe a complete image auto-extraction algorithm capable of scanning e-holovideos and generating a directory of extracted, focussed bitmap-images.

30. Veitch R, Hendry DC, Watson J, *Reconfigurable hardware applied to Holographic Reconstruction*, **Proc OCEANS07 Aberdeen, 071031-016**, (2008)³⁰.

Digital holography has the potential to record three dimensional images of the subsea environment. Digital holographic cameras are capable of recording large amounts of data in a single session. Reconstruction of these holograms and extraction of useful data can be very time consuming using current software reconstruction systems. Hardware reconstruction using a reconfigurable computer has been investigated and a

pipelined Fresnel transform has been designed with the potential to reconstruct holographic video in real time.

31. P Benzie, H Sun, J Watson, *Holographic Image Acquisition...*, **Proc OCEANS07 Aberdeen, 070131-040**, (2008)³¹

Currently there are two approaches to large volume data retrieval for underwater holography: optical methods using high-resolution emulsions or digital holography. Underwater digital holography has enabled high-resolution real-time data to be obtained with depths-of-field otherwise unobtainable by conventional non-holographic optical techniques. However, conventional photographic-based methods provide large volume retrieval at a superior resolution. The authors discuss a twin camera automated image retrieval system for in-line photo-holographic reconstruction and future alternative real-time reconstruction methods using digital holography. In both techniques image acquisition and data retrieval from reconstructed holograms presents a number of challenges that hinder the ability to readily extract information. The automated holographic reconstruction system has been developed to aid the analysis, databasing and identification of objects captured by in-line holography, whereas, the digital off-axis system presents an alternative real-time visualisation approach for underwater analysis.

Digital off-axis real-time reconstruction using numerical pre-processing of captured holograms for data extraction and visualization using a spatial light modulator (SLM) is presented. This method has the advantage of recording surface information and optimizing the recording quality of holograms in-situ without the necessity of numerical post-processing. Preliminary experiments have demonstrated optical and numerical reconstructions at interactive frame rates. Observed interlacing artefacts caused by the CCD camera used are presented and discussed. Optical and numerical reconstructions using a spatial light modulator are outlined as are Fourier methods using a negative Laplacian finite impulse response filter to pre-process holograms for optimizing the numerical and optical reconstruction.

Editors comment: The above three papers relate to numerical reconstruction of the holograms. The first looks at method of autofocus and automation of the data extraction from digital holograms. The second talks about implementing the reconstruction process in programmable gate arrays. The third talks about the problems common to both classical photo-based holography and its electronic counterpart and how they can be addressed. Together they represent significant activity in holographic reconstruction whether or not it is applied underwater.

32. V Dyomin, J Watson, P Benzie, *Reducing aberrations of holographic images of underwater particles.....*, **Proc OCEANS07 Aberdeen 070131-036** (2008)³²

In this paper, the authors describe a method of recording by combining back-illumination of in-line objects with an off-axis reference beam to produce low-aberration holograms. This is advantageous since at the reconstruction stage no extra means of refractive-index compensation are required. Calculations have shown that the spherical aberration does not exceed 5% for objects from 100 to 200 μm at a wavelength of 0.532 μm , the longitudinal spherical aberration does not exceed 1%, and astigmatism does not exceed 1%. A series of holograms were recorded to confirm

the above predictions. Two targets consisting of arrays of squares, triangles, hexagons, rectangles and circles with dimensions of 100 μm and 200 μm were fabricated on glass plates by photolithography. Holograms were recorded with the objects placed in air or in water at various distances. After processing, holograms were replayed at 0.633 μm and at 0.542 μm . More than 100 images were compared with the original targets for shape, dimensions and evidence of aberrations. Corresponding particles sizes differ by no more than 10%. The above experiments allow the authors to conclude that use the off-axis scheme with normal incidence of object beam on holoplates can provide a reduction of aberrations without any additional compensation at reconstruction stage.

Editors comment: This paper discusses an alternative means of recording classical holograms in water to those presented earlier which has the potential to remove the need for index-compensation in the laboratory. It is not yet known whether this is a practical alternative.

Following on from the above work, the Aberdeen team have also been developing digital holography for medical applications such as the dynamics of fast-moving blood cells. Digital video holography is growing importance for such applications and allows the mapping of blood flow.

33. H Sun, B Song, H Dong, B Reid, J Watson, MA Player, M Zhao, *Visualisation of fast moving cells in vivo with digital holographic microscopy*, accepted for **Jnl of Biomedical Engineering 13** (2008)³³

Digital in-line holography offers some significant advantages over conventional optical holography and microscopy to image biological specimens. By combining holography with digital video microscopy, an in-line holographic video microscope is developed and is capable of recording spatial 3D holographic images of biological specimens, while preserving the time dimension. The system enables high-speed video recording of fast cell movement, such as the rapid movement of blood cells in the blood stream in vivo. This capability is demonstrated with observations of fast 3-D movement of live cells in suspension cultures in response to a gentle shake to the Petri dish. The experimental and numerical procedures are incorporated with a fast reconstruction algorithm for reconstruction of holographic video frames at various planes *_z axis_* from the hologram and along the time axis. The current system enables both lateral and longitudinal resolutions down to a few micrometers. Post reconstruction processing of background subtraction is utilized to eliminate noise caused by scattered light, thereby enabling visualization of, for example, blood streams of live *Xenopus* tadpoles. The combination of digital holography and microscopy offers unique advantages for imaging of fast moving cells and other biological particles in three dimensions in vivo with high spatial and temporal resolution.

34. Sun,H.; Song,B.; Ou,J; Watson,J.; and Zhao,M. *Digital holography for imaging tissue cells using coherent lights*, in “**Digital Holography and Three-Dimensional Imaging**” Paper PDPJMA8, OSA Technical Digest (CD), March 17-19, (Optical Socy of America 2008)³⁴

Visible and near-infrared lasers are examined to see how laser coherence length and wavelength affect the image quality in digital holographic microscopy. With opaque and partially transparent animal tissues, NIR-lasers show advantages over visible lasers.

Editors comment: Both of these papers (33, 34) represent another important application of digital holography in the field of biomedical imaging. This work springs from the earlier work on underwater holographic and extends these techniques to holographic video-microscopy.

4 Conclusions

In this the final report of WP12, we have outlined the work that has been done within each of the major Tasks outlined in the current DoW. The roadmaps (holography and underlying technologies, autostereo, applications and education) first introduced into the NoE have been updated and enhanced. These roadmaps have been (and will continue to be) a useful start point for any future research work related to 3DTV; they help, crucially, to identify any roadblocks which need to be overcome or surmounted if any of these developments are to come to fruition. They indicate where new research work could and should be targeted. For example, if holographic 3DTV is to become a reality then clearly improvements in SLM performance are necessary. For autostereo, then head tracking continues to be an important issue, as does the availability of suitable light sources. Human factors continue to be a major factor in the development of a 3D display, it is true to say that no current implementation of 3D technology has yet been able to overcome all the aspects which affect public acceptance, comfort and perception.

In the lifetime of the NoE, developments in 3D displays have progressed dramatically; many new displays are actually on the market deploying some of the techniques we have discussed, such as holography, vision-assisted stereo and autostereo. Some of these systems have been introduced by the big market companies like *Philips* and *Mitsubishi*. It is still far from clear though which, if any, of these systems will corner the market or if we will eventually see a holo-autostereo hybrid.

Over the course of the NoE, members of WP12 have been instrumental in generating some significant achievements in displays and applications. The roadmap concept is one. Our input in areas of SLM application, photopolymers, novel autostereo and head-tracking; implications of human factors and means of evaluating them; have all helped to progress the science and technology of 3D displays. Several of our participants have formed groups (sometimes with outside partners) that have applied for, and received, prestigious funding awards from national or international bodies.

We have also presented and discussed some of the recent publications from WP12 members. These are given with a short editorial comment that puts the publication into context. The papers represent a wide range of activities from applications of SLM's in computer-generated holography to studies of the human factors; from head-tracking to new types of autostereo display. The applications papers are equally wide-ranging from forest-fire simulation to underwater holography.

In summary, the success and impact of the work in WP12 has had, and is continuing to have, far-reaching influence across the whole gamut of worldwide 3DTV and vision. We have made significant progress in the development of our field. The Task summaries and associated papers offer an overview of progress made by the network in displays and applications. We believe that the 3DTV Network has proven to be a catalyst to pave the way for the development of the associated display technologies and their applications over the next ten years.

5 ANNEX (References for 3DTV Partners)

- ¹ Benzie, P., Watson, J., Surman, J., Rakkolainen, I., Hopf, K., Urey, H., Sainov, V., von Kopylow, C., *3DTV Displays: Techniques and Technologies*. **Trans CSVT** **17**, 1647-1658, (2007)
- ² Lukas Ahrenberg, Philip Benzie, Marcus Magnor and John Watson *Computer generated holograms from three dimensional meshes using an analytic light transport model* **App Opt** **47**, 1567 – 1574 (2008)
- ³ Murat Sayinta, Serhan O. Isikman, Hakan Urey, *Scanning LED Array based Volumetric Display* **IEEE 3DTV-CON 2008**, Istanbul (May 2008).
- ⁴ Veysel Yücesoy, Doruk Tunaoglu, Metodi Kovachev, Rossitza Ilieva, Levent Onural, *Design and Implementation of a DMD based volumetric 3D Display*, **IEEE 3DTV-CON 2008**, Istanbul (May 2008)
- ⁵ Fahri Yaras, Metodi Kovachev, Rossitza Ilieva, Mostafa Agour, Levent Onural, *Holographic Reconstruction using Phase-only Spatial Light Modulators*, **IEEE 3DTV-CON 2008**, Istanbul (May 2008)
- ⁶ Elena Stoykova, Ventseslav Sainov, Georgi Minchev *3D Scene capture by Multi-wavelength pattern projection at divergent illumination of a sinusoidal phase grating*, **IEEE 3DTV-CON 2008** Istanbul (May 2008)
- ⁷ T. Yovcheva, I. Naydenova, I. Vlaeva, R. Todorov, V. Toal, S. Sainov, *Optical properties of charged polymer with nano-sized zeolite inclusions* **Jnl Optoelectronics and advanced materials** (in press, 2008)
- ⁸ T. Yovcheva, K. Beev, TZ. Petrova, V. Dragnostinova, G. Mekishev, and S. Sainov, *Electric charge influence on holographic recording in photopolymers* **Journal of Optoelectronics and Advanced Materials** (In press 2008)
- ⁹ Edward Buckley, Alex Corbett Phil Surman, Ian Sexton, *Multi-Viewer Autostereoscopic Display with Dynamically-addressable Holographic Backlight*, **SID2008** (2008)
- ¹⁰ Ian Sexton, Edward Buckley, *ATTEST to MUTED – Problems, Answers, and the Evolution of a Multiple Mobile Viewer Autostereoscopic Display* **IMID 2008** (2008)
- ¹¹ Phil Surman, Ian Sexton, Klaus Hopf, Wing Kai Lee, Edward Buckley, Graham Jones, Richard Bates, *European Research into Head Tracked Autostereoscopic displays*, **IEEE 3DTV-CON 2008** Istanbul (May 2008)
- ¹² Phil Surman, Ian Sexton, Klaus Hopf, Wing Kai Lee, Edward Buckley, Graham Jones, Richard Bates, *Laser-based Multi-user 3D Display*, **ASID'07**, Singapore (Aug 2007)
- ¹³ Phil Surman, Ian Sexton, Klaus Hopf, Wing Kai Lee, Edward Buckley, Graham Jones, Richard Bates, *Laser-based Multi-user 3D Display*, Extended version of paper at ASID'07, Singapore, **Jnl SID**, 16/6 (2008)
- ¹⁴ Klaus Hopf, Paul Chojecki, Frank Neumann *Novel User Interaction Technologies in 3D Display Systems*, **IEEE 3DTV-CON 2008** Istanbul (May 2008)

-
- ¹⁵ Xenophon Zabulis, Nikos Grammalidis, Yalin Bastanlar, Erdal Yilmaz, Yasemin Yardimci Cetin, *3D Scene Reconstruction Based on Robust Camera Motion Estimation and Space Sweeping for a Cultural Heritage Virtual Tour System* **IEEE 3DTV-CON 2008** Istanbul (May 2008)
- ¹⁶ Yalin Bastanlar, Erdal Yilmaz, Yasemin Yardimci Cetin, Nikos Grammalidis, Xenophon Zabulis, Georgios Triantafyllidis, *3D Reconstruction for a Cultural Heritage Virtual Tour System*, **IEEE 3DTV-CON 2008**, Istanbul, (May 2008)
- ¹⁷ Yalin Bastanlar, Erdal Yilmaz, Yasemin Yardimci Cetin Nikos Grammalidis, Xenophon Zabulis, Georgios Triantafyllidis, *3D Reconstruction for a Cultural Heritage Virtual Tour System*, **ISPRS 2008**
- ¹⁸ Kivanc Kose, Nikolaos Grammalidis, Erdal Yilmaz, and Enis Cetin *3D Forest Fire Propagation Simulation* **IEEE 3DTV-CON 2008** Istanbul (May 2008)
- ¹⁹ Kivanc Kose, Erdal Yilmaz, Nikolaos Grammalidis, Bahadir Aktug, A. Enis Cetin , Ilhami Aydin, Boyutlu Orman Yangini Sistemi, *3D Forest-Fire Spread Simulation System* **IEEE 3DTV-CON 2008** Istanbul (May 2008)
- ²⁰ Kivanc Kose, Enis Cetin, Erdal Yilmaz, Nikos Grammalidis *3D Wildfire Simulation System*, **ISPRS 2008**
- ²¹ Olwal, A., DiVerdi, S., Rakkolainen, I., Höllerer, T., Consigalo: *Multi-user, Face-to-face Interaction on an Immaterial Display with Adaptive Audio*. **Second International Conference on INtelligent TEchnologies for interactive enterTAINment INTETAIN 2008**. Cancun, Mexico, (January 2008).
- ²² Rakkolainen, I., *Measurements and Experiments of Immaterial Virtual Reality Display*. **IEEE 3DTV-CON 2008** Istanbul, (May 2008).
- ²³ Rakkolainen, I., *Recent Developments in the Immaterial Projection Screen technology* (poster), *Society for Information Displays (SID 2008)*. Los Angeles, (May 2008).
- ²⁴ Rakkolainen, I., *Display screen based on particles carried in a fluid stream*. Patent Application **PCT/FI2007/050364** (June 2007)
- ²⁵ Jumisko-Pyykkö, S. Hellsten, S. Weitzel, M., Rakkolainen, I., *Children's Game Experiences in Different Settings*. **IEEE 3DTV-CON 2008**, Istanbul, (May 2008).
- ²⁶ H Sun, DC Hendry, MA Player, J Watson, *In situ Underwater Holographic Camera for Studies of Plankton*, **Jnl Oceanic Eng**, **32**, 373-383 (2007)
- ²⁷ H Sun P Benzie, N Burns, D Hendry, M Player, J Watson , *Underwater digital holography for studies of marine plankton*, **Phil Trans Roy Soc** **366**, 1789-1806 (2008)
- ²⁸ H Sun, D Hendry, N Burns, J Watson *Ocean plankton imaging using*, **Proc OCEANS07 Aberdeen, 070417-040**, (Aberdeen 2007)
- ²⁹ N Burns, M Player, J Watson *Data extraction from underwater holograms of marine organisms* , **Proc OCEANS07 Aberdeen, 070130-004**, (Aberdeen 2007)

-
- ³⁰ Vietch R, Hendry DC, Watson J, *Reconfigurable hardware applied to Holographic Reconstruction*, **Proc OCEANS07 Aberdeen Oceans07, 071031-016**, (Aberdeen 2007)
- ³¹ P Benzie, H Sun, J Watson *Holographic Image Acquisition...*, **Proc OCEANS07 Aberdeen, 070131-040**, (Aberdeen 2008)
- ³² V Dyomin, J Watson, P Benzie *Reducing aberrations of holographic images of underwater particles.....*, **Proc OCEANS07 Aberdeen 070131-036** (Aberdeen 2007)
- ³³ H Sun, B Song, H Dong, B Reid, J Watson, MA Player, M Zhao *Visualisation of fast moving cells in vivo with digital holographic microscopy*, accepted for **Jnl of Biomedical Engineering 13** (2008)
- ³⁴ Sun,H.; Song,B.; Ou,J; Watson,J.; and Zhao,M. *Digital holography for imaging tissue cells using coherent lights*, in “**Digital Holography and Three-Dimensional Imaging**” Paper PDPJMA8, **OSA Technical Digest (CD)**, March 17-19, (Optical Socy of America 2008)
- ³⁵ Erdem, Tanju. **Three Dimensional Television: Consumer Market Survey**